

Microcontrollers
Toshiba Microcontrollers with LCD Controller
~ Product Guide ~

September 2008
Rev. 1.6

TOSHIBA CORPORATION
Semiconductor Company

TMP91C815FG



Standard 16-bit microcontroller with LCD controller, RTC, memory management unit (MMU), and melody alarm function

● TLCS-900/L1 CPU Core

- Operating voltage : 1.8 to 3.6 V
- Minimum instruction execution time : 148 ns (27 MHz/2.7 V)
400 ns (10 MHz/1.8 V)
- Power-saving features : Clock gear
Dual clocks
Standby modes
(IDLE2, IDLE1, STOP modes)

● Built-in Functions

- LCD controller : 1 channel (monochrome)
- 10-bit AD converter : 8 channels
- RTC : 1 channel
- 8-bit timer : 4 channels
- UART/SIO : 2 channels
(One of the channels supports IrDA*.)
- SBI/I²C : 1 channel
- Watchdog timer : 1 channel
- Memory management unit (MMU) : Up to 136 Mbytes

* IrDA: Infrared communication standards developed by the Infrared Data Association

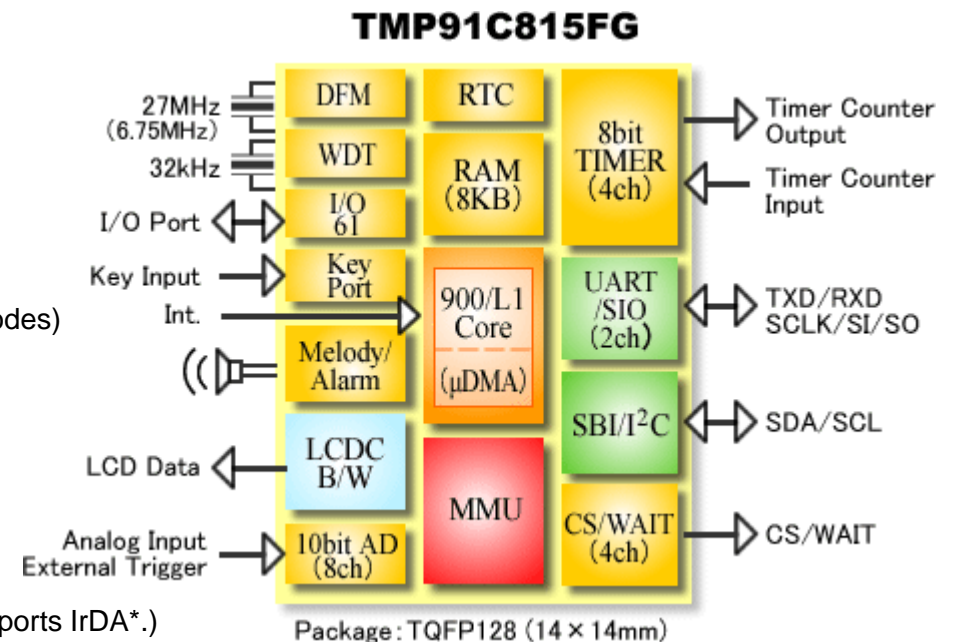

Memory Size

Part Number	ROM	RAM
TMP91C815FG	None	8 Kbytes

TMP91C016FG



16-bit microcontroller with EDO DRAM controller and voltage detector

● TLCS-900/L1 CPU Core

- Operating voltage : 1.8 to 3.6 V
- Minimum instruction execution time : 148 ns (27 MHz/2.7 V)
400 ns (10 MHz/1.8 V)
- Power-saving features : Clock gear
Dual clocks
Standby modes
(IDLE2, IDLE1, STOP modes)

● Built-in Functions

- HVC (Horizontal Vertical Converter) : 1 channel
- LCD controller : 1 channel (monochrome)
- VLD (Voltage Level Detector) : 3 channels
- RTC : 1 channel
- 8-bit timer : 4 channels
- UART/SIO : 1 channel
- UART/IrDA1.0 : 1 channel (115.2 Kbps)
- EDO DRAM controller : 1 channel
- Watchdog timer : 1 channel
- Memory management unit (MMU) : Up to 105 Mbytes

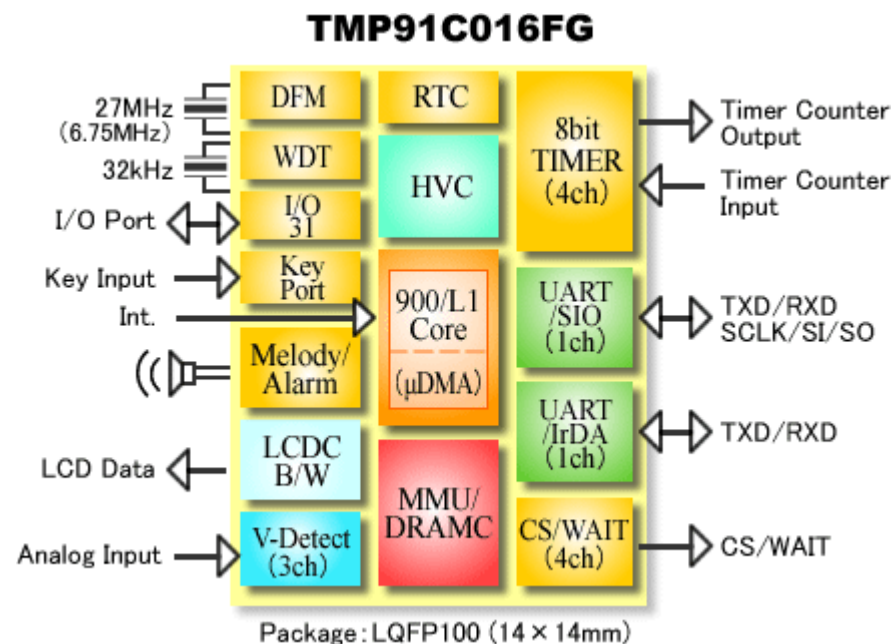

Memory Size

Part Number	ROM	RAM
TMP91C016FG	None	None

TMP91C025FG



16-bit microcontroller supporting touch screen interface

● TLCS-900/L1 CPU Core

- Operating voltage : 2.7 to 3.6 V
- Minimum instruction execution time : 111 ns (36 MHz/3.0 V)
148 ns (27 MHz/2.7 V)
- Power-saving features : Clock gear
Dual clocks
Standby modes (IDLE2, IDLE1, STOP modes)

● Built-in Functions

- LCD controller : 1 channel (monochrome)
- 10-bit AD converter : 4 channels
- RTC : 1 channel
- 8-bit timer : 4 channels
- UART/SIO : 2 channels
(One of the channels supports IrDA.)
- Watchdog timer : 1 channel
- Memory management unit (MMU) : Up to 72 Mbytes
- Touch screen interface : 1 channel

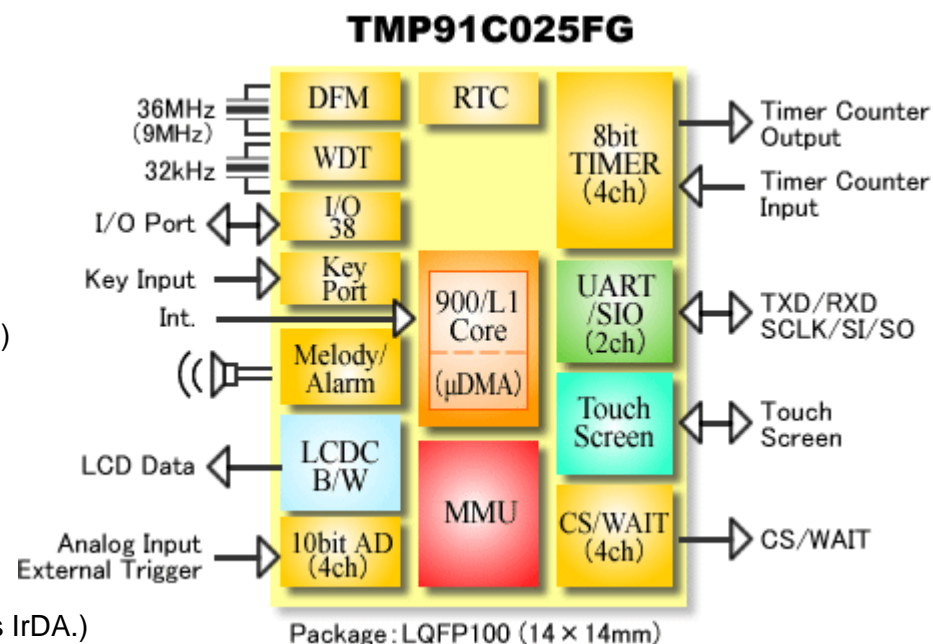

Memory Size

Part Number	ROM	RAM
TMP91C025FG	None	None

TMP91C820AFG



16-bit microcontroller with LCD controller and SDRAM controller supporting 16-level grayscale and 4096-color display

● TLCS-900/L1 CPU Core

- Operating voltage : 2.7 to 3.6 V
- Minimum instruction execution time : 111 ns (36 MHz/3.0 V)
148 ns (27 MHz/2.7 V)
- Power-saving features:
 - Clock gear
 - Dual clocks
 - Standby modes (IDLE2, IDLE1, STOP modes)

● Built-in Functions

- SDRAM controller : Up to 128 Mbits
- LCD controller : 1 channel (16-level grayscale)
- 10-bit AD converter : 8 channels
- RTC : 1 channel
- 8-bit timer : 4 channels
- 16-bit timer : 1 channel
- UART/SIO : 2 channels
- SIO/IrDA1.0 : 1 channel (115.2 Kbps)
- SBI/I²C : 1 channel
- Watchdog timer : 1 channel
- Memory management unit (MMU) : Up to 136 Mbytes

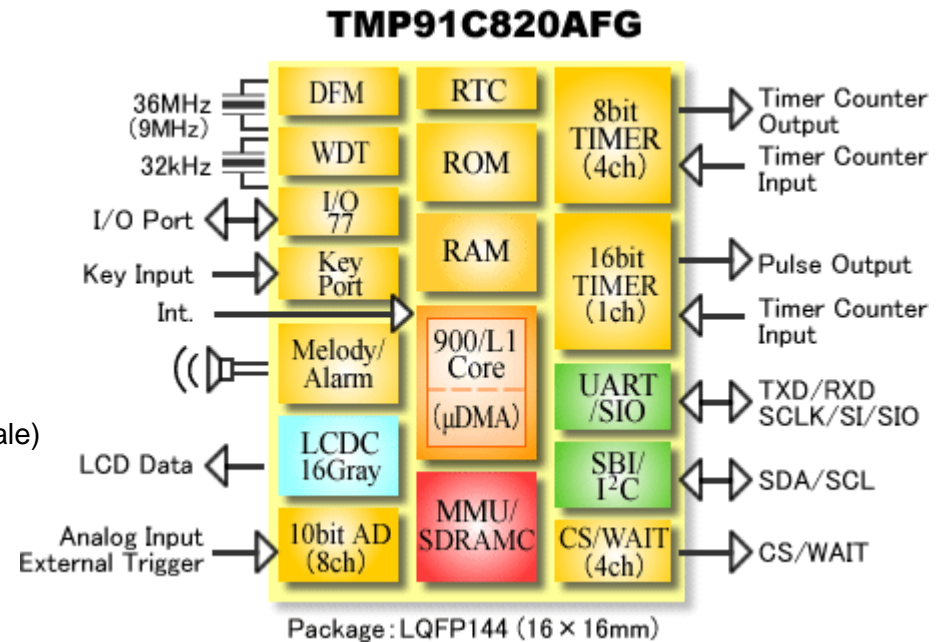

Memory Size

Part Number	ROM	RAM
TMP91C820AFG	8 Kbytes	8 Kbytes

TMP92C820FG



32-bit microcontroller based on high-performance 900/H1 core

● TLCS-900/H1 CPU Core

- Operating voltage : 3.0 to 3.6 V
- Minimum instruction execution time : 50 ns (internal 20 MHz)
- Power-saving features : Clock gear
Dual clocks
Standby modes (IDLE2, IDLE1, STOP modes)

● Built-in Functions

- SDRAM controller : Up to 128 Mbits
- LCD controller : 1 channel (16-level grayscale)
- 10-bit AD converter : 5 channels
- RTC : 1 channel
- 8-bit timer : 4 channels
- 16-bit timer : 1 channel
- UART : 1 channel
- UART/SIO : 2 channels
(One of the channels supports IrDA.)
- SBI/I²C : 1 channel
- Watchdog timer : 1 channel
- Memory management unit (MMU) : Up to 136 Mbytes

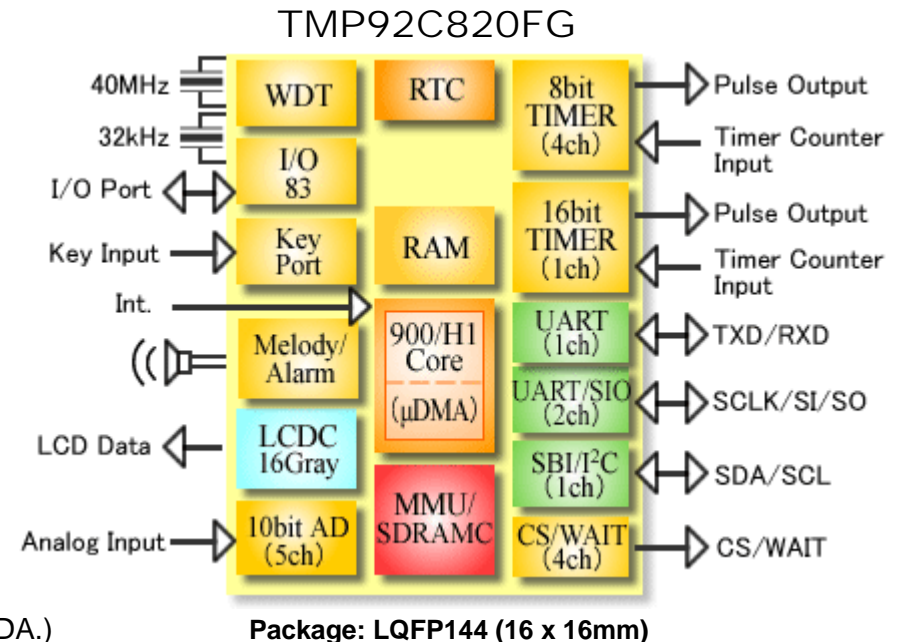

Memory Size

Part Number	ROM	RAM
TMP92C820FG	None	8 Kbytes

TMP92CH21FG



32-bit microcontroller with color LCD controller, USB control, and NAND Flash ROM interface

● TLCS-900/H1 CPU Core

- Operating voltage : 3.0 to 3.6 V
- Minimum instruction execution time : 50 ns (internal 20 MHz)
- Power-saving features : Clock gear
Dual clocks
Standby modes

● Built-in Functions

- USB device controller : 1 channel
- SDRAM controller : Up to 512 Mbits
- Color LCD controller (4096/TFT 4096/STN) : 1 channel
- NAND Flash ROM interface : 2 channels (128M x 2)
- I²S interface : 1 channel
- 10-bit AD converter : 4 channels
- RTC : 1 channel
- 8-bit timer : 4 channels
- 16-bit timer : 1 channel
- UART/SIO : 2 channels
(One of the channels supports IrDA.)
- Watchdog timer : 1 channel
- Touch screen interface : 1 channel
- Memory management unit (MMU) : Up to 512 Mbytes

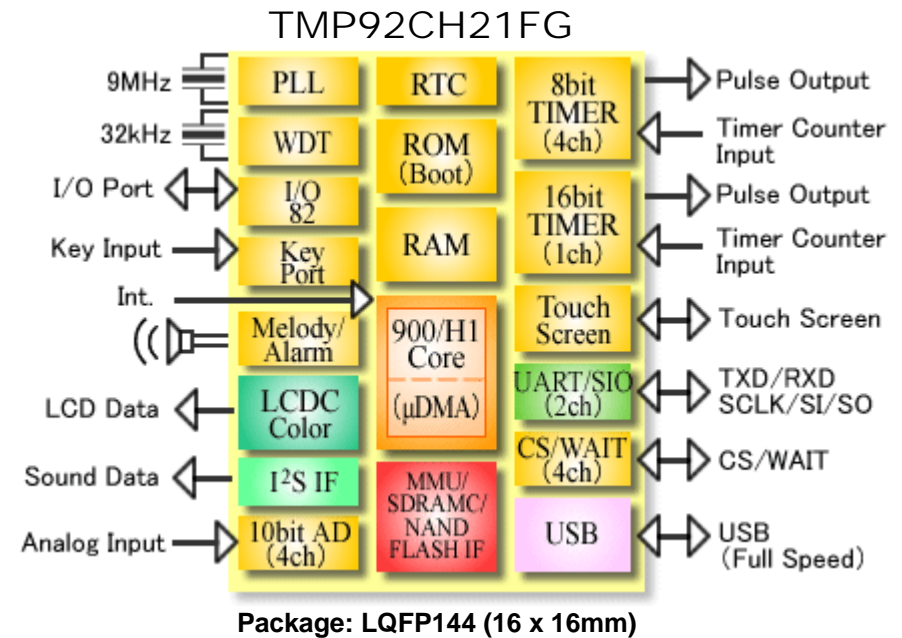

Memory Size

Part Number	ROM	RAM
TMP92CH21FG	8 Kbytes (Boot)	16 Kbytes

TMP92CA25FG



32-bit microcontroller with monochrome LCD controller and NAND Flash ROM interface

● TLCS-900/H1 CPU core

- Operating voltage : 3.0 to 3.6 V
- Minimum instruction execution time : 50 ns (internal 20 MHz)

● Built-in Functions

- SPI (Serial Peripheral Interface) : 1 channel
- SDRAM controller : Up to 512 Mbits (display & program execution)
- LCD controller : 1 channel (monochrome)
- NAND Flash ROM interface : 2 channels (128M x 2)
- I²S interface : 1 channel
- 10-bit AD converter : 4 channels
- RTC : 1 channel
- 8-bit timer : 4 channels
- 16-bit timer : 1 channel
- UART/SIO : 1 channel
- I²C : 1 channel
- Watchdog timer : 1 channel
- Touch screen interface : 1 channel
- Memory management unit (MMU) : Up to 512 Mbytes (One of the channels supports IrDA.)

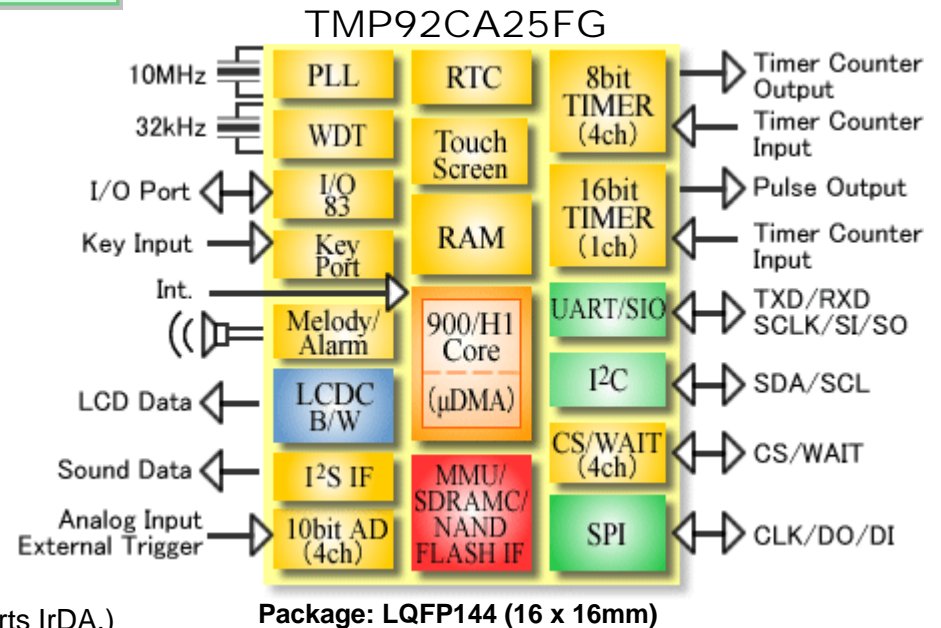

Memory Size

Part Number	ROM	RAM
TMP92CA25FG	None	10 Kbytes

TMP92CZ26AXBG



32-bit microcontroller with 0.18um process 900/H1 core and large-capacity RAM, capable of operating at 80 MHz (four times faster than existing 900/H1 products)

● **TLCS-900/H1 CPU Core (0.18 um)**

- Operating voltage : Internal 1.4 to 1.6 V, I/O 3.0 to 3.6 V
- Minimum instruction execution time : 12.5 ns (internal 80 MHz)
- Power-saving features : Clock gear
Dual clocks
Standby modes

● **Built-in Functions**

- Color LCD controller : 1 channel (16M/TFT 64K/STN)
- MLC/SLC NAND Flash ROM interface: 2 channels (128M x 2)
- MAC (multiply-accumulate unit) : 1 channel (32 x 32 + 64 = 64 bits)
- USB (full-speed) device controller : 1 channel
- SDRAM controller : Up to 512 Mbits
- I²S interface : 2 channels
- 10-bit AD converter : 6 channels
- DMA controller : 6 channels
- SPI (SD card) : 1 channel
- RTC : 1 channel
- 8-bit timer : 8 channels
- 16-bit timer : 2 channels
- UART/SIO : 1 channel
- Watchdog timer : 1 channel
- Touch screen interface : 1 channel
- Memory management unit (MMU) : Up to 3.1 Gbytes

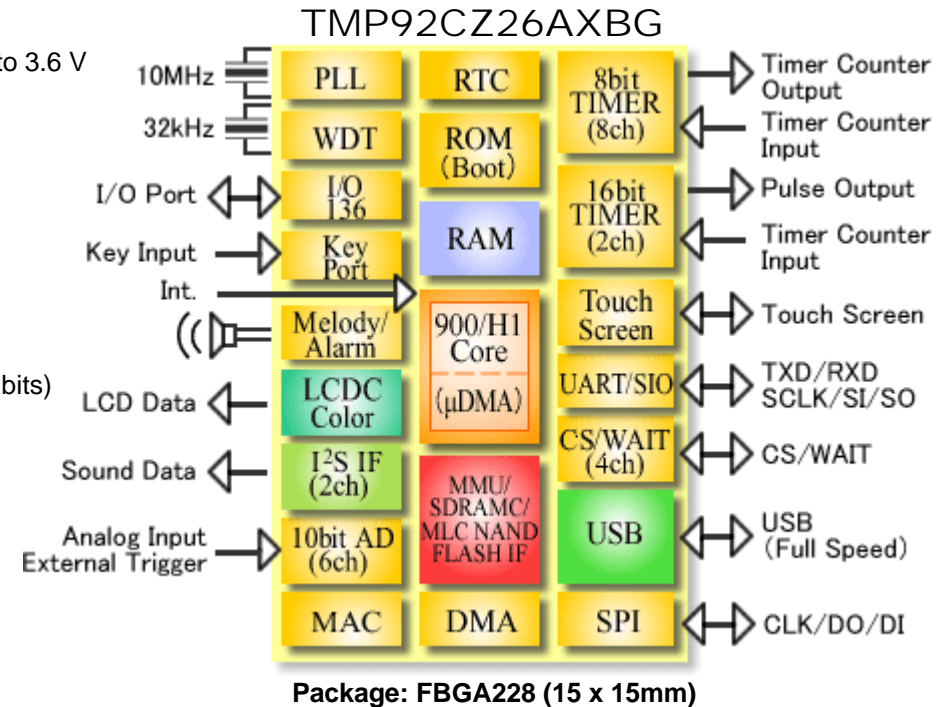

Product Lineup

Part Number	ROM	RAM
TMP92CF26AXBG	8 Kbytes (Boot)	144 Kbytes
TMP92CZ26AXBG	8 Kbytes (Boot)	288 Kbytes

TMP92CF29AFG



High-speed advanced 32-bit microcontroller with large capacity RAM and color LCD controller capable of operating at 80MHz

● **TLCS-900/H1 CPU Core (0.18 um)**

- Operating voltage : Internal 1.4 to 1.6 V, I/O 3.0 to 3.6 V
- Minimum instruction execution time : 12.5 ns (internal 80 MHz)

● **Built-in Functions**

- Color LCD controller : 1 channel (64K/TFT 64K/STN)
- MLC/SLC NAND Flash ROM interface: 2 channels (128M x 2)
- MAC (multiply-accumulate unit) : 1 channel (32 x 32 + 64 = 64 bits)
- USB (full-speed) device controller : 1 channel
- SDRAM controller : Up to 512 Mbits
- I²S interface : 1 channel
- 10-bit AD converter : 6 channels
- DMA controller : 6 channels
- SPI* (SD card) : 1 channel
- RTC : 1 channel
- 8-bit timer : 8 channels
- 16-bit timer : 2 channels
- UART/SIO : 2 channels
- Watchdog timer : 1 channel
- Touch screen interface : 1 channel
- Memory management unit (MMU) : Up to 2.1 Gbytes

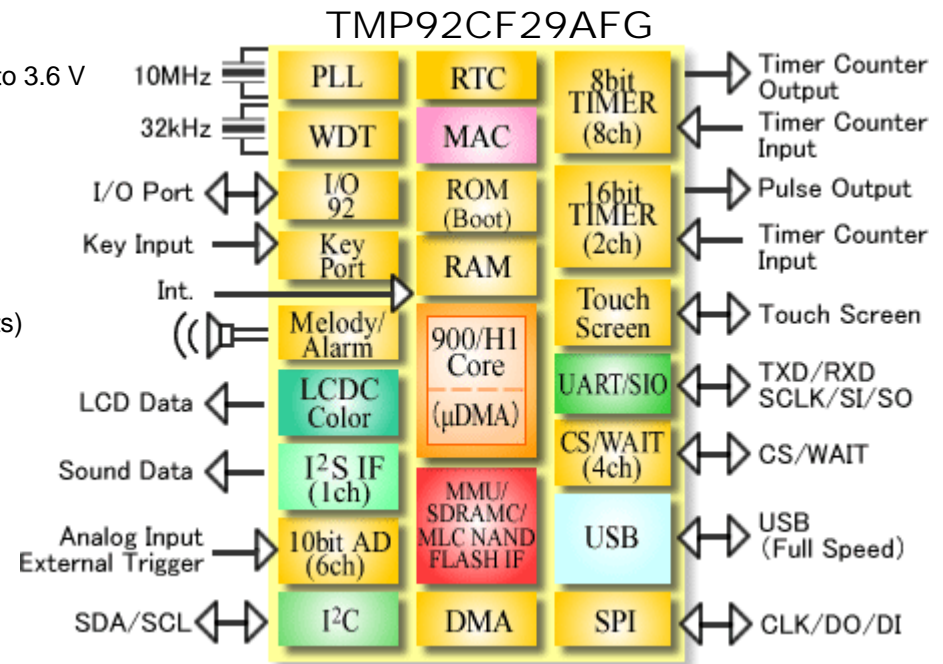

Package: LQFP176 (20 x 20mm)

Memory Size

Part Number	ROM	RAM
TMP92CF29AFG	8 Kbytes (Boot)	144 Kbytes

* SPI : Serial Peripheral Interface

-
- The information contained herein is subject to change without notice. 021023_D
 - Toshiba is continually working to improve the quality and reliability of its products. Nevertheless, semiconductor devices in general can malfunction or fail due to their inherent electrical sensitivity and vulnerability to physical stress. It is the responsibility of the buyer, when utilizing TOSHIBA products, to comply with the standards of safety in making a safe design for the entire system, and to avoid situations in which a malfunction or failure of such TOSHIBA products could cause loss of human life, bodily injury or damage to property. In developing your designs, please ensure that TOSHIBA products are used within specified operating ranges as set forth in the most recent TOSHIBA products specifications.
Also, please keep in mind the precautions and conditions set forth in the "Handling Guide for Semiconductor Devices", or "TOSHIBA Semiconductor Reliability Handbook" etc. 021023_A
 - The TOSHIBA products listed in this document are intended for usage in general electronics applications (computer, personal equipment, office equipment, measuring equipment, industrial robotics, domestic appliances, etc.). These TOSHIBA products are neither intended nor warranted for usage in equipment that requires extraordinarily high quality and/or reliability or a malfunction or failure of which may cause loss of human life or bodily injury ("Unintended Usage"). Unintended Usage include atomic energy control instruments, airplane or spaceship instruments, transportation instruments, traffic signal instruments, combustion control instruments, medical instruments, all types of safety devices, etc. Unintended Usage of TOSHIBA products listed in this document shall be made at the customer's own risk. 021023_B
 - The products described in this document shall not be used or embedded to any downstream products of which manufacture, use and/or sale are prohibited under any applicable laws and regulations. 060106_Q
 - The information contained herein is presented only as a guide for the applications of our products. No responsibility is assumed by TOSHIBA for any infringements of patents or other rights of the third parties which may result from its use. No license is granted by implication or otherwise under any patents or other rights of TOSHIBA or the third parties. 070122_C
 - Please contact your sales representative for product-by-product details in this document regarding RoHS compatibility. Please use these products in this document in compliance with all applicable laws and regulations that regulate the inclusion or use of controlled substances. Toshiba assumes no liability for damage or losses occurring as a result of noncompliance with applicable laws and regulations. 060819_Z
 - The products described in this document may include products subject to the foreign exchange and foreign trade control laws. 060925_F
 - The products described in this document may contain components made in the United States and subject to export control of the U.S. authorities. Diversion contrary to the U.S. law is prohibited. 021023_H
 - TOSHIBA has made this document deliberately in order to make its contents as accurate as possible. Nevertheless, if any trouble should occur due to any error contained in this document, TOSHIBA shall not have any liability therefore. Also, please keep in mind the precautions and conditions set forth in the "Instruction Manual or Operation Manual of TOSHIBA Products," or "The Precautions or Procedure Files described in the Installation Disk such as Floppy Disk or CD-ROM etc." Please constantly pay attention to the latest information on the TOSHIBA products which is to be released through the web page of TOSHIBA microcomputer development system.
(<http://www.semicon.toshiba.co.jp/eng>) 060824_N

TOSHIBA

TOSHIBA CORPORATION
Semiconductor Company
Website: <http://www.semicon.toshiba.co.jp/eng>