

TOSHIBA

Leading Innovation >>>

Microcontrollers

Toshiba Microcontrollers for DSLRs/DVCs

~ Functions and Features ~

January 2008

Rev. 1.4

TOSHIBA CORPORATION
Semiconductor Company

Toshiba Microcontrollers for DSLRs/DVCs

Toshiba microcontrollers for DSLRs^{*}/DVCs^{**} provide various functions to support the technologies of our customers.

We are committed to creating a better and high-quality future.

For DSLR/DVC applications, Toshiba offers an extended lineup of high-performance 32-bit RISC microcontrollers:

TX19 Family (TX19 Series, TX19A Series)

featuring high-speed multiply-accumulate (MAC) operations, high-speed AD converters and high-capacity ROM.



DSLRs

DVCs



* DSLR : Digital Single-Lens Reflex (Camera)
** DVC : Digital Video Camera

Toshiba Large-Capacity Microcontroller Roadmap



Toshiba offers an extended lineup of microcontrollers suitable for controlling DSLR/DVC applications.

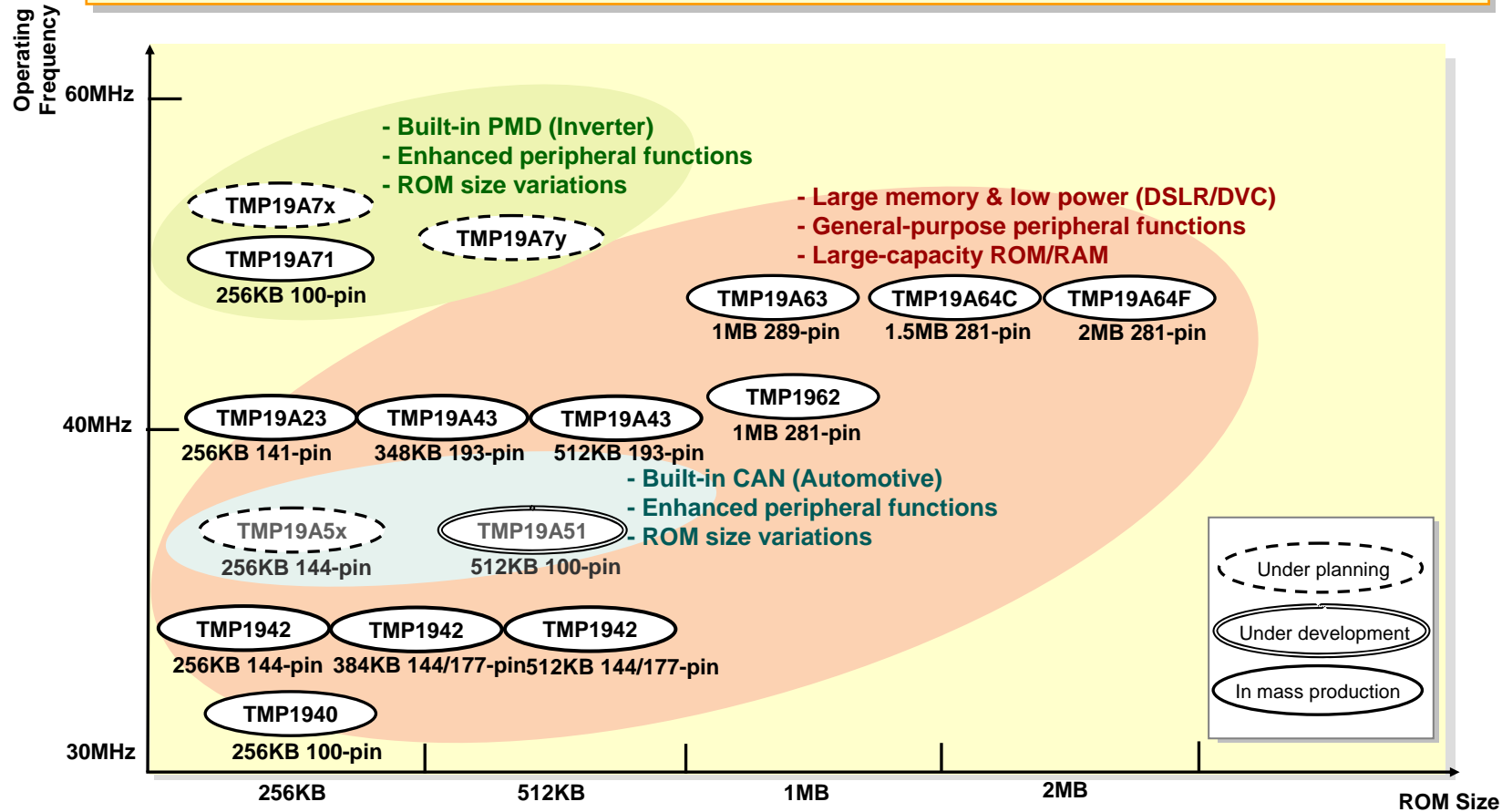

Products with flash memory are also available. For details, please contact your local Toshiba sales representative.

Features of TX19 Family

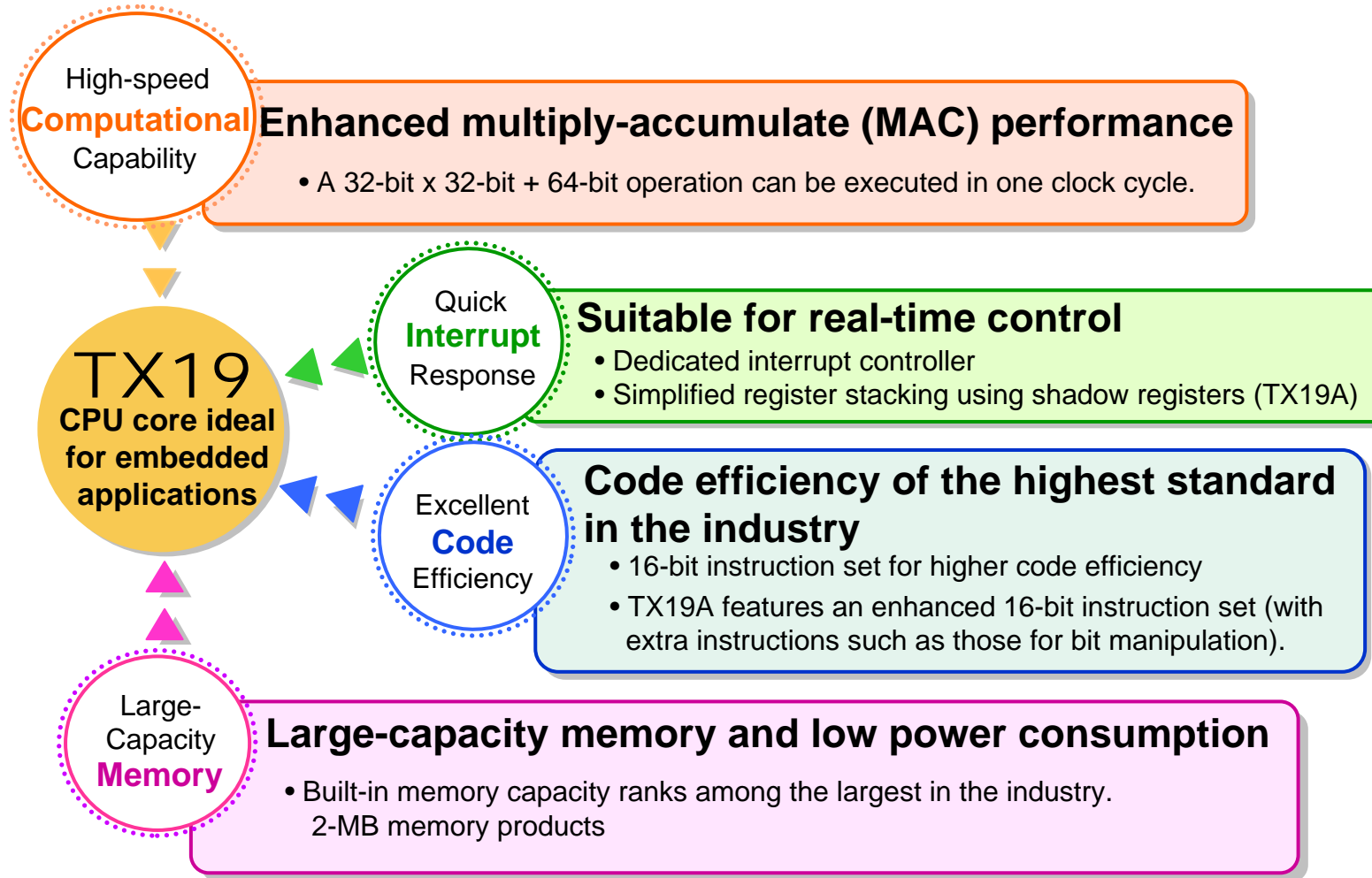

TX19 Family Feature: High-Speed Computational Capability



Enhanced MAC performance

A 32-bit x 32-bit + 64-bit operation can be executed in one clock cycle.

When not using MAC

1. 32-bit x 32-bit → 2 clock cycles

```
MULT    r2, r6, r7
MFHI    r3
```

2. 64-bit + 64-bit → 4 clock cycles

```
ADDU    r10, r2, r4
SLTU    r11, r10, r2
ADD(U)  r11, r11, r3
ADD(U)  r11, r11, r5
```

Total: 6 clock cycles



When using MAC

32-bit x 32-bit + 64-bit

```
MADD    r4, r6, r7
```

Can be executed in one clock cycle by the dedicated MAC unit.

Suitable for applications requiring high-speed computations

TX19 Family Feature: Quick Interrupt Response

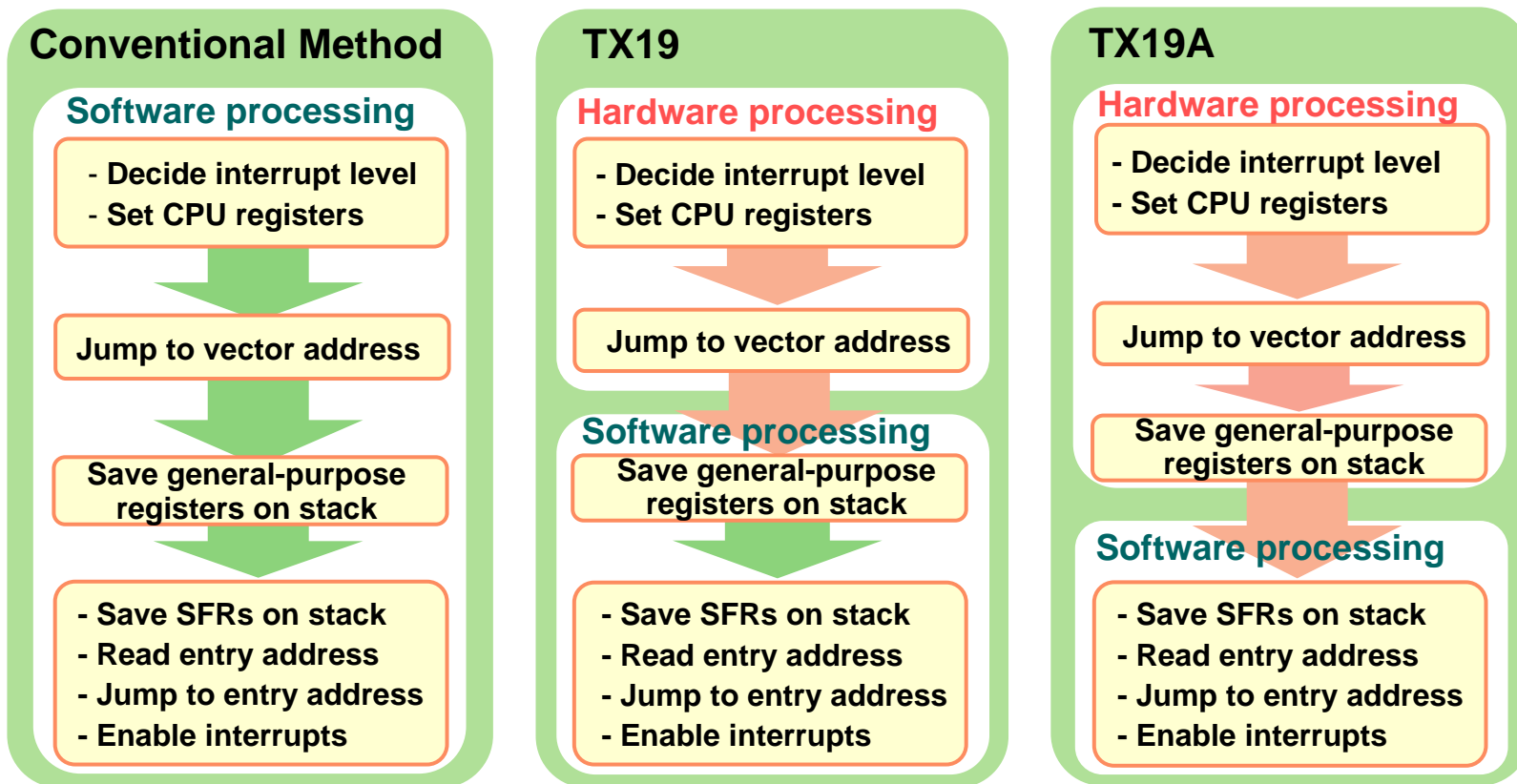

Use of hardware for part of interrupt processing



Automated interrupt processing
Reduced burden on software

TMP19A43 Suitable for DSLRs



The TMP19A43 includes features that can realize **a complete set of camera control sequences.**

- Computation and control capabilities optimized for camera control
- Controlling and communicating with other LSIs
- Application control
- Low power consumption features suitable for battery-driven applications

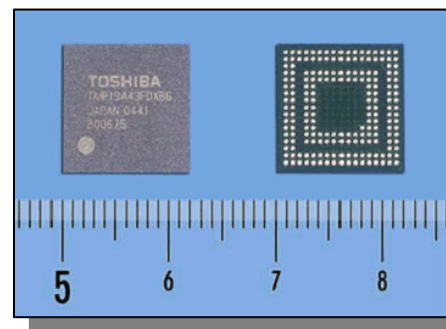

TMP19A43

Features of TMP19A43 (1)



High-speed computations

Excellent MAC performance

A 32-bit x 32-bit + 64-bit operation can be executed in one clock cycle.

TX19 excels in MAC.

Analog functions best suited for sensor processing

- High-speed AD converter
10-bit resolution, 16 channels of analog input (conversion time: 1.15 μ s)
- DA converter
8-bit resolution, 2 channels

Fast conversion time

Various built-in functions

- Key-on wake-up: 32 channels (with dynamic pull-up for reducing power consumption) providing a total of 48 channels of external interrupts together with INT interrupts
- Other multi-channel functions (SIO, timer, and more)
HSIO (10 Mbps) : 3 channels (supporting high-speed E2PROM)
- Two-phase input counter for dial input: 4 channels
- Motor control by PPG (PWM) synchronous start control
- ROM correction : 8 words x 4 blocks
- Programmable pull-up supported for all inputs/outputs

Features of TMP19A43 (2)



Faster AD conversion and MAC operations

The high-speed AD converter enables faster conversion of analog signals from a sensor.

The MAC unit can process a 32-bit x 32-bit + 64-bit operation in one clock cycle.

Faster analog signal processing

These enhanced processing capabilities enable quick focusing.

Low power consumption

Various operating modes are available for reducing power consumption during standby.

The dynamic pull-up function enables power saving at key input.

Reduced battery consumption

Battery operating time can be prolonged.

Features of TMP19A43 (3)



● 48 channels of interrupts suitable for camera control (mode change, switch input)

- External interrupt : 16 channels
- Key input : 32 channels (with dynamic pull-up)

● Multiple timers suitable for camera system control

16-bit timer x 16 channels, 32-bit free-running timer

- 32-bit free-running timer : 1 channel
 - Output compare register : 8 channels
 - Input capture register : 4 channels
- 16-bit timer
 - Can be used for multiple functions (interval timer, event counter, capture, PPG output: every 4 channels, synchronous outputs are possible)
 - Four channels can be used as 2-phase pulse input counters.

● 7 channels of serial interfaces suitable for camera control

- UART/SIO: 4 channels (1 channel = I²C /SIO)
- UART/HSIO: 3 channels (10 Mbps (max.))
 - Capable of high-speed data transfer to E2PROM

Features of TMP19A43 (4)



● **Contains 2 channels of 2-input dial input counter (2-phase pulse input counter) to support camera applications.**

Can be used in NORMAL, SLOW and SLEEP modes.

- The CPU wakes up from SLEEP mode by a count input. (This input is counted.)
- The CPU wakes up from STOP mode by a count input. (This input is not counted.)
- Count values are captured by software.
- Up/down interrupts can be generated. (Overflow/underflow conditions can be detected by flags.)

[Count Operation] Normal operation mode or Quadruple mode can be selectable

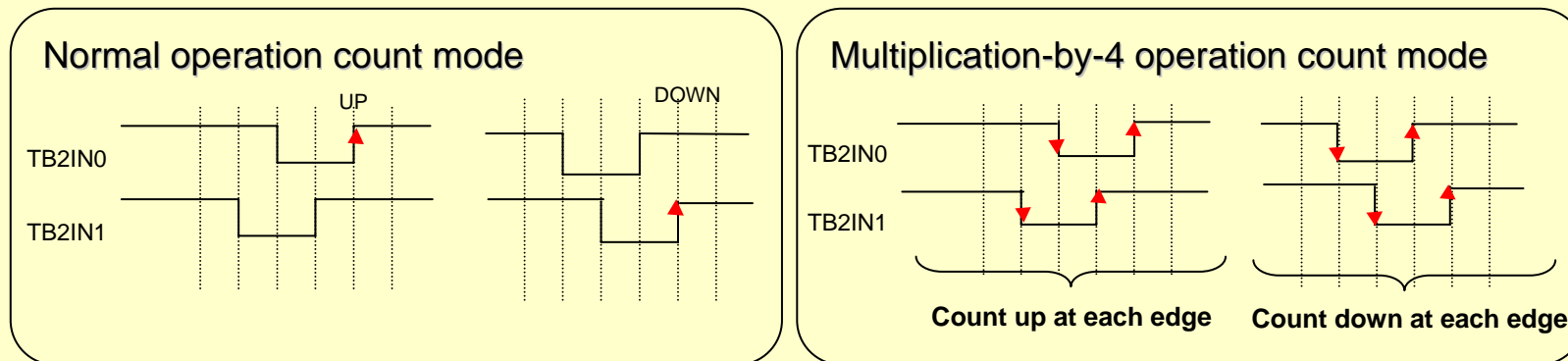

* Interrupt timing is programmable (every edge or every fourth edge).

Features of TMP19A43 (5)

● Low power consumption features

In SLOW and SLEEP modes

- RTC, 2-phase pulse input counter, dynamic pull-up operation

Dynamic pull-up (for reducing current consumption at key input)

- Programmable pull-up at key input (Low level) is available (enable/disable).
- In SLOW and SLEEP modes, dynamic pull-up can be enabled or disabled.
- In NORMAL and STOP modes, only static pull-up can be enabled or disabled.

[Dynamic Pull-Up]

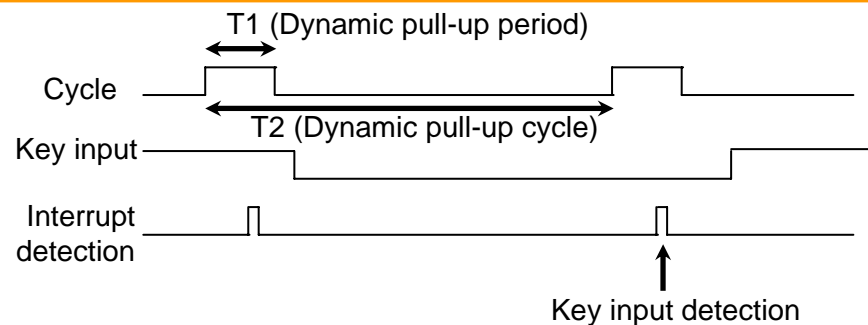

Interrupts can be generated on both edges.
External pin status can be monitored also in dynamic pull-up mode.

DSLR Application System Example

Toshiba offers a complete system environment with a variety of peripheral functions.

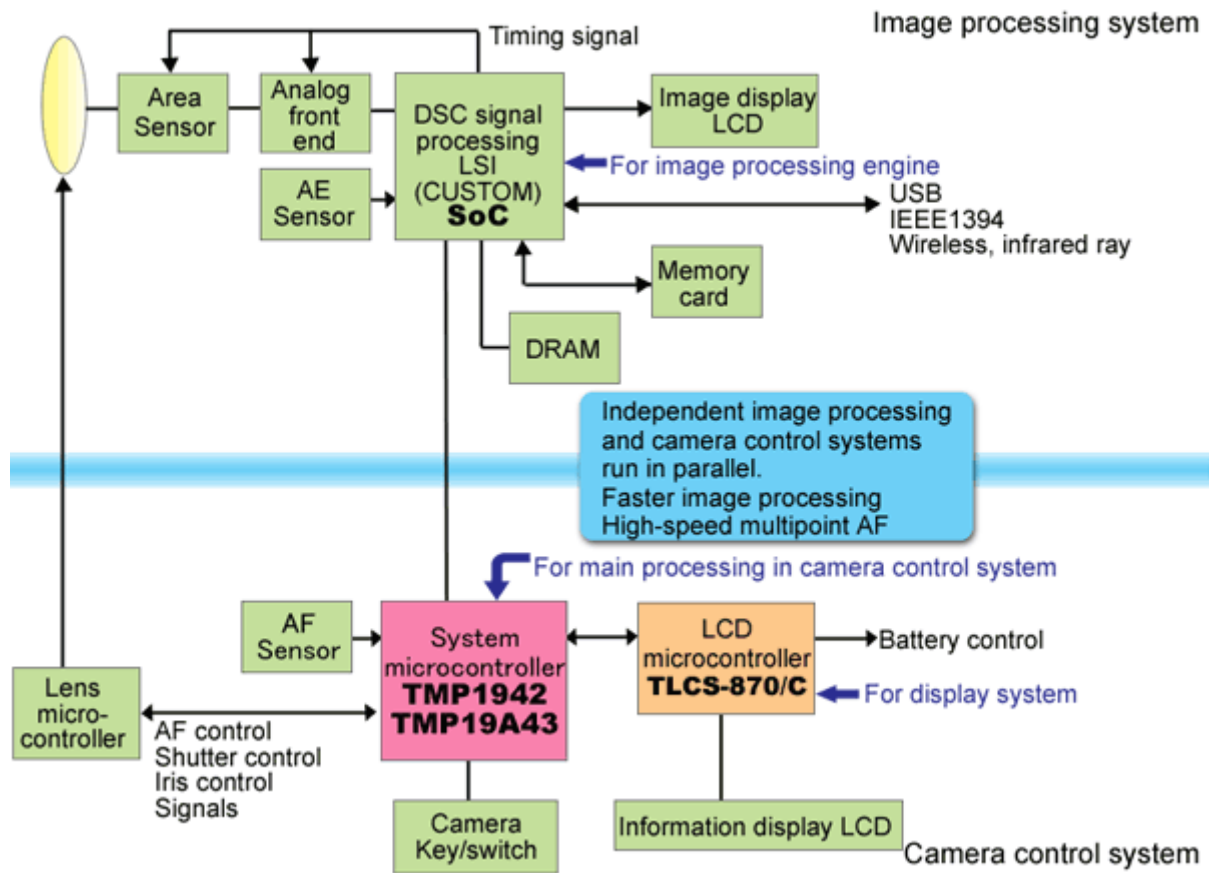

Toshiba Microcontrollers for DVCs



To keep pace with ever advancing technology in the DVC field,

Toshiba is continuously working toward smaller, lighter microcontrollers with less power consumption which will help customers assemble DVCs with a smaller number of parts.

The TX19 Family of microcontrollers offer various functions best suited for controlling DVC systems.

- **Multipin interface**
- **Efficient performance**
- **Large-capacity built-in ROM**
- **Low power consumption**



TMP1964F20BXBG

Camera control, Shutter control,
AF control, Tape control

Features of TMP19A64



Single-chip 32-bit RISC microcontroller for real-time control

The TMP19A64 is a 32-bit RISC microcontroller based on the TX19A core and incorporating large-capacity ROM and RAM. The microcontroller's low voltage operation and low power consumption make it ideal for battery-driven applications such as portable information devices.

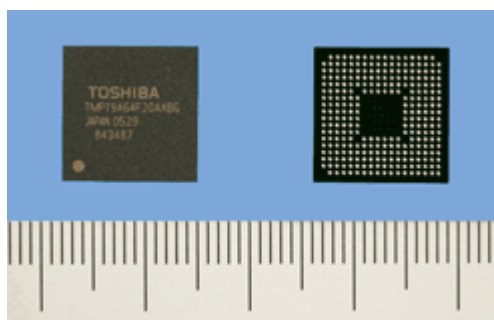

TMP19A64

DVC Application Example

The TMP19A64 contains 2 Mbytes of large-capacity Flash ROM, making it possible to store software for controlling the camera and deck blocks on a single chip. A total of 209 I/O pins are available so that multiple peripheral ICs can be controlled efficiently.

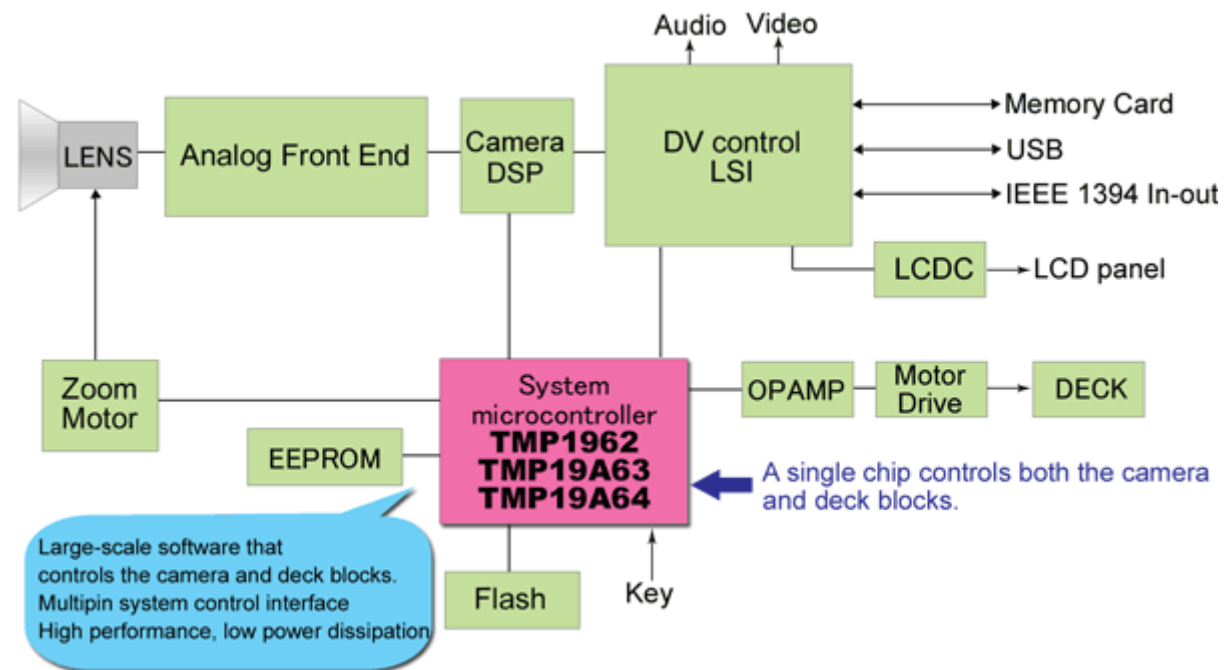

TOSHIBA

Leading Innovation >>>

Microcontrollers

Toshiba Microcontrollers for DSLRs/DVCs

~ Product Guide ~

January 2008

Rev. 1.4

TOSHIBA CORPORATION
Semiconductor Company

TMP1942



TX19 Family 32-bit microcontroller with high-speed 10-bit AD converter supporting low power consumption

- **TX19 CPU Core**
 - Operating voltage : Internal, I/O, ADC = 2.7 to 3.6 V (Mask/Flash)
 - Maximum operating frequency : 32 MHz (8 MHz × 4 by PLL)
 - DSP function : 32-bit multiply-accumulate (MAC) operations take only one clock cycle to execute.
 - DSU (Debug Support Unit) : Supports breakpoint and PC trace functions.
 - Power saving operation : Dual clocks
Clock gear (for dividing the clock by 2, 4, or 8)
Standby modes (IDLE, SLEEP, STOP modes)
- **Built-in Functions**
 - 10-bit AD converter : 16 channels (conversion time: 2 μs)
 - 10-bit DA converter : 3 channels
 - DMA controller : 4 channels (memory-to-memory, memory-to-I/O, I/O-to-memory transfers)
 - 8-bit timer : 12 channels (PWM: 6 channels)
 - 16-bit timer : 14 channels (Two channels can be used as 2-phase pulse input counters.)
 - Serial interface : SIO/UART: 5 channels, I²C/SIO: 1 channel
 - Address/data bus : 16-/8-bit (multiplexed bus)
 - Key-on wake-up : 14 channels (with dynamic pull-up)
 - ROM correction : 8 words x 4 blocks
 - 5 V port : 15 pins

TMP1942CYUE
TMP1942CZUE/TMP1942CZXBG
TMP1942FDU/TMP1942FDXBG

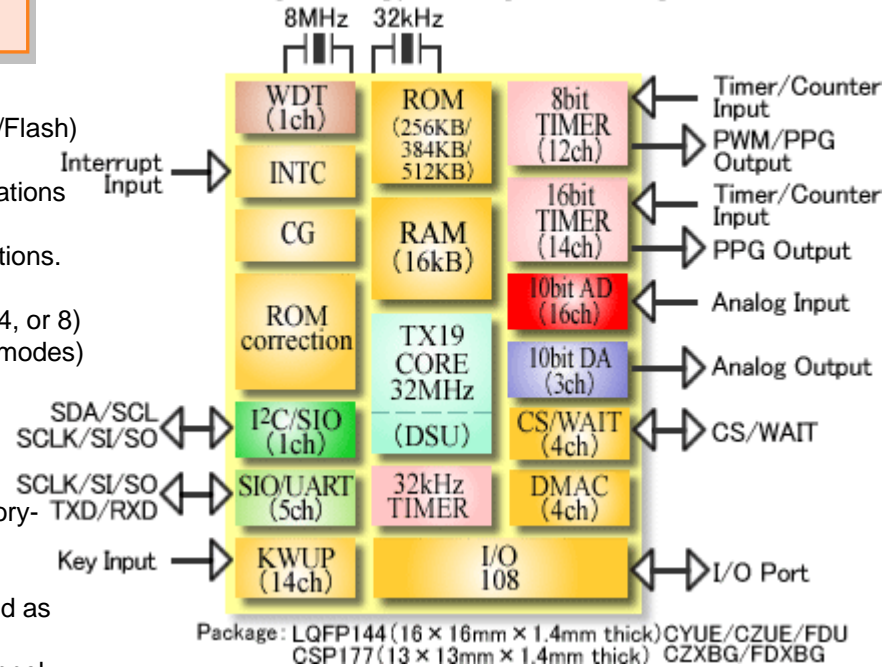

Product Lineup

Part Number	ROM	RAM
TMP1942CYUE	256 KB (Mask)	16 KB
TMP1942CZUE/TMP1942CZXBG	384 KB (Mask)	16 KB
TMP1942FDU/TMP1942FDXBG*	512 KB (Flash)	20 KB

* Samples available

TMP1962



Single-chip 32-bit high-performance RISC microcontroller containing industry's largest 1-MB Flash memory/Mask ROM

● TX19 CPU Core

- Operating voltage : Internal = 1.35 to 1.65 V (Mask), 2.3 to 2.7 V (Flash)
I/O = 1.65 to 3.3 V, ADC = 2.7 to 3.3 V
- Maximum operating frequency : 40.5 MHz (13.5 MHz × 3 by PLL)
- DSP function : 32-bit multiply-accumulate (MAC) operations take only one clock cycle to execute.
- DSU (Debug Support Unit) : Supports breakpoint and PC trace functions.
- Power saving operation : Clock gear (for dividing the clock by 2, 4 or 8) Standby modes (IDLE, STOP modes)

● Built-in functions

- 10-bit AD converter : 24 channels (sequential comparison type, conversion time: 8 μs)
- DMA controller : 8 channels (memory-to-memory, memory-to-I/O, I/O-to-memory transfers)
- 8-bit timer : 12 channels (8-/16-/24-/32-bit cascade connection)
- 16-bit timer : 4 channels (Two channels can be used as 2-phase pulse input counters.)
- 32-bit timer : 1 channel 32-bit input capture: 8 registers
32-bit output compare: 8 registers
- Serial interface : SIO/UART: 7 channels, I²C/SIO: 1 channel
- Address/data bus : 16-/8-bit (multiplexed/separate bus selectable)
- Key-on wake-up : 14 channels
- ROM correction : 8 words x 8 blocks

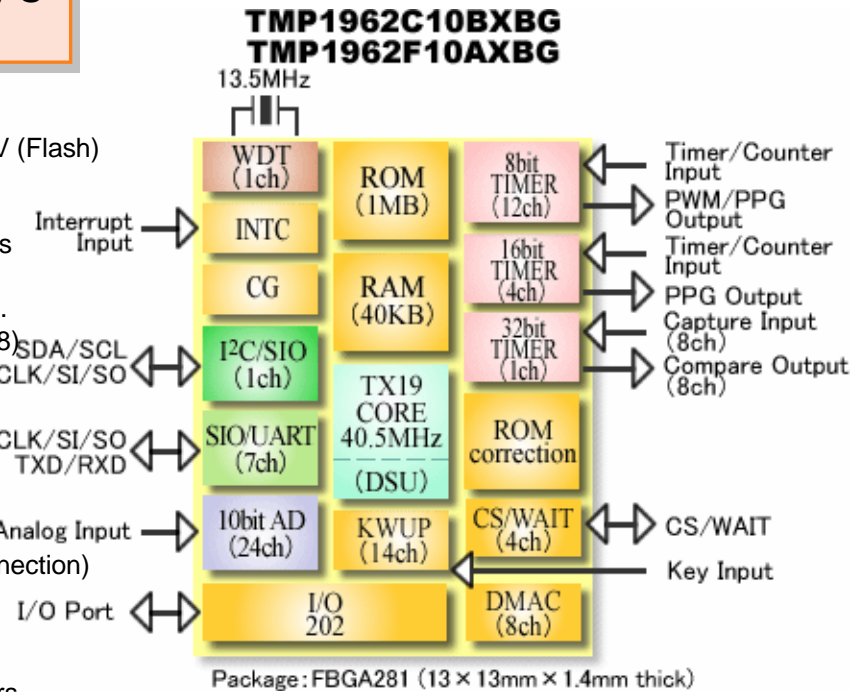

Product Lineup

Part Number	ROM	RAM
TMP1962F10AXBG	1 MB (Flash)	40 KB
TMP1962C10BXBG	1 MB (Mask)	40 KB

TMP19A23FYXBG NANO FLASH™



32-bit RISC microcontroller with high-precision PPG, high-speed AD converter, and HSIO supporting low power consumption

● TX19A CPU Core

- Operating voltage : Internal = 1.35 to 1.65 V, Peripheral I/O = 2.7 to 3.6 V
- Maximum operating frequency: 40 MHz (10 MHz × 16 ÷ 4)
- DSP function : 32-bit multiply-accumulate (MAC) operations take only one clock cycle to execute.
- Debug function (EJTAG): Supports breakpoint, PC trace and PD trace.
- Power saving operation: Clock gear (for dividing clock to 1/2, 1/4, or 1/8) Standby modes (IDLE, STOP modes)

● Built-in Functions

- 10-bit AD converter : 13 channels (conversion time: 1.15 μs at 40 MHz)
- DMA controller : 4 channels
- 16-bit timer : 10 channels (1 channel can be used as 2-phase pulse input counters.)
- High-precision PPG : 2 channels
- Serial interface : SIO/UART : 3 channels
HSIO/UART : 1 channel
I²C/SIO : 2 channels
- 5V-tolerant I/O : 11 ports
- Address/data bus : 8-/16-bit (multiplexed/separate selectable)
- ROM correction : 8 words x 12 blocks
- External interrupt : 15 channels

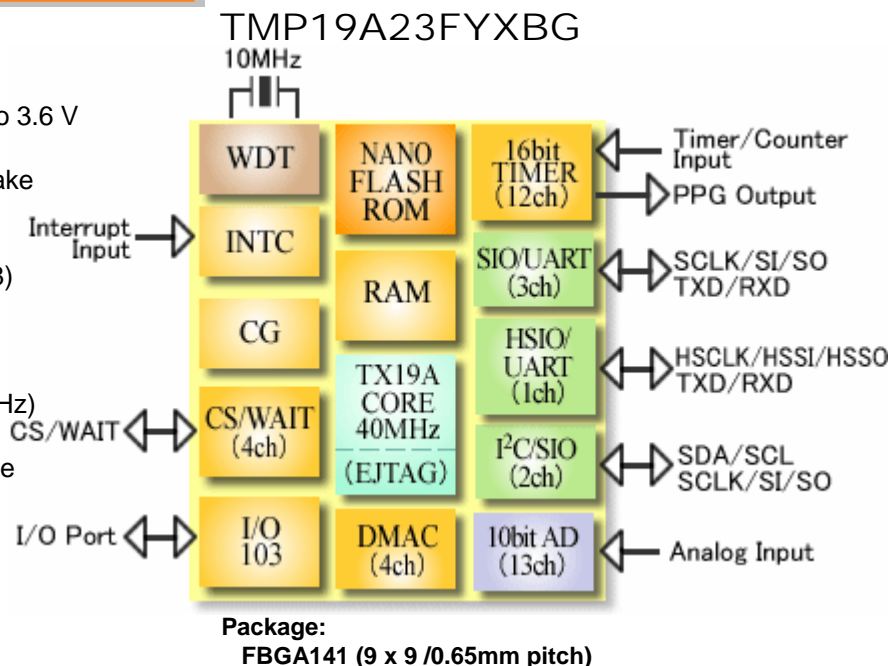

Product Lineup

Part Number	ROM	RAM
TMP19A23FYFG	256 KB (Flash)	24 KB
TMP19A23FYXBG	256 KB (Mask)	24 KB

TMP19A43

NANO FLASH™



32-bit RISC microcontroller with HISO and analog functions enhanced by high-speed AD converter and DA converter supporting low power consumption

● TX19A CPU Core

- Operating voltage : Internal = 1.5 V, Peripheral I/O = 2.7 to 3.6 V
DAC = 2.3 to 2.7 V, ADC = 2.7 to 3.6 V
- Maximum operating frequency: 40 MHz (10 MHz × 4 by PLL)
- DSP function : 32-bit multiply-accumulate (MAC) operations take only one clock cycle to execute.
- Debug function (EJTAG): Supports breakpoint, PC trace and PD trace.
- Power saving operation : Dual clocks
Clock gear (for dividing clock to 1/2, 3/4, 1/4, or 1/8)
Standby modes (IDLE, SLEEP, STOP modes)

● Built-in Functions

- 10-bit AD converter : 16 channels (conversion time: 1.15 μs)
- 8-bit DA converter : 2 channels (2.5 V)
- DMA controller : 8 channels (memory-to-memory, memory-to-I/O, I/O-to-memory transfers)
- 16-bit timer : 16 channels (4 channels can be used as 2-phase pulse input counters.)
- 32-bit timer : 1 channel 32-bit input capture: 4 registers
32-bit output compare: 8 registers
- Serial interface : SIO (5 Mbps)/UART: 4 channels (1 channel = I²C/SIO)
HSIO (10 Mbps)/UART: 3 channels
- Address/data bus : 8-/16-bit (multiplexed/separate selectable)
- Key-on wake-up : 32 channels (with dynamic pull-up)
- ROM correction : 1 word x 8 blocks, 8 words x 4 blocks
- External interrupt : 16 channels

TMP19A43FDXBG/FZXBG
TMP19A43CDXBG/CZXBG

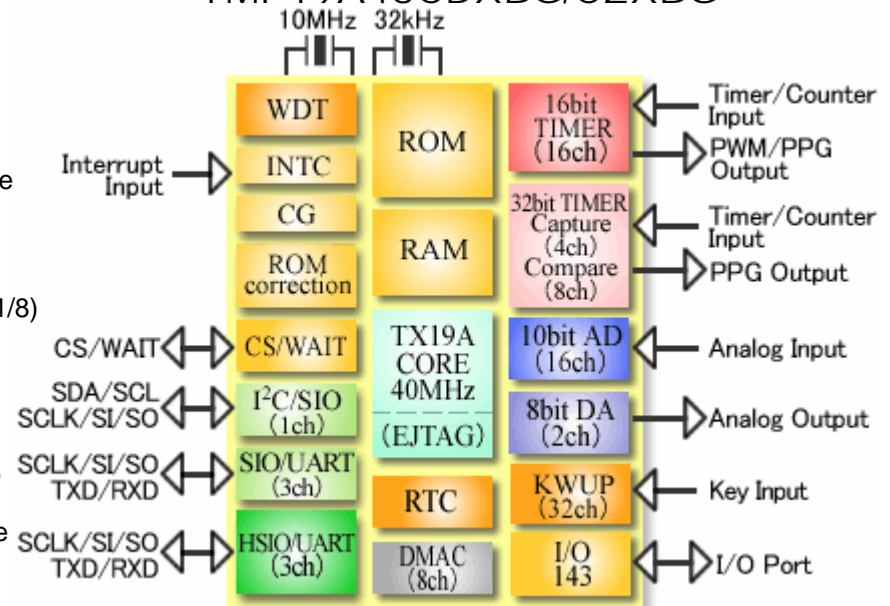

Package:
FBGA193 (12 x 12 /0.65mm pitch)

Product Lineup

Part Number	ROM	RAM
TMP19A43FDXBG	512 KB (Flash)	24 KB
TMP19A43FZXBG	384 KB (Flash)	20 KB
TMP19A43CDXBG	512 KB (Mask)	24 KB
TMP19A43CZXBG	384 KB (Mask)	20 KB

TMP19A63

NANO FLASH™



32-bit high performance RISC microcontroller with various timers and serial interfaces supporting low power consumption

● TX19A CPU Core

- Operating voltage : Internal = 1.35 to 1.65 V, Peripheral I/O = 1.65 to 3.3 V
ADC = 2.7 to 3.3 V
- Maximum operating frequency: 54 MHz (13.5 MHz × 4 by PLL)
- DSP function : 32-bit multiply-accumulate (MAC) operations take only one clock cycle to execute.
- Debug function (EJTAG): Supports breakpoint, PC trace and PD trace.
- Power saving operation : Dual clocks
Clock gear (for dividing clock to 1/2, 1/4, or 1/8)
Standby modes (IDLE, STOP modes)

● Built-in Functions

- 10-bit AD converter : 32 channels (conversion time: 1.15 μs at 40 MHz)
- DMA controller : 8 channels (memory-to-memory, memory-to-I/O, I/O-to-memory transfers)
- 16-bit timer : 36 channels (4 channels can be used as 2-phase pulse input counters.)
- 32-bit timer : 2 channels 32-bit input capture: 4 registers
32-bit output compare: 4 registers
- Serial interface : SIO/UART: 11 channels
I²C/SIO: 2 channels
- Address/data bus : 8-/16-bit (multiplexed/separate selectable)
- Key-on wake-up : 8 channels (with dynamic pull-up)
- ROM correction : 8 words x 12 blocks
- External interrupt : 20 channels

TMP19A63F10XBG

TMP19A63C10XBG/CZXBG

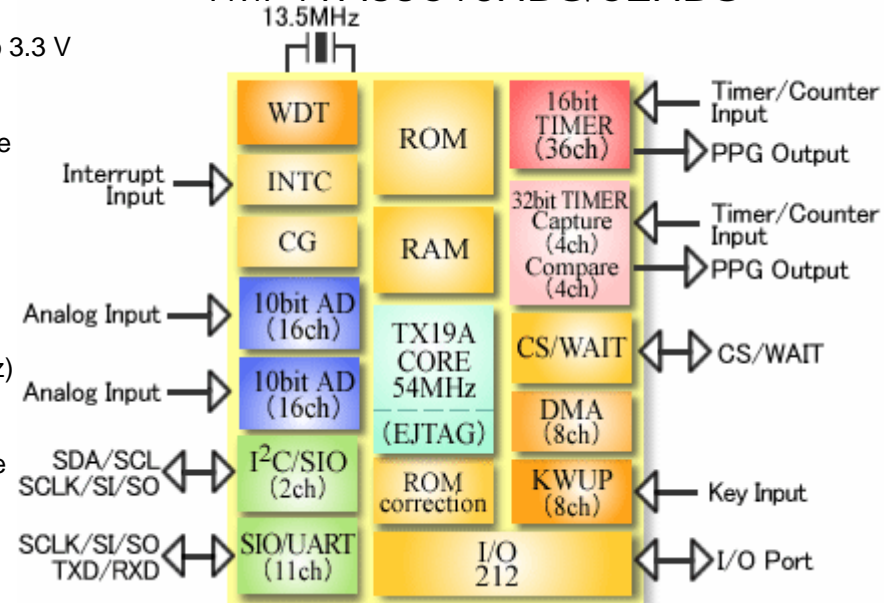

Package:

FBGA289 (11 x 11 /0.5mm pitch)

Product Lineup

**Under planning

Part Number	ROM	RAM
TMP19A63F10XBG	1 MB (Flash)	48 KB
TMP19A63C10XBG++	1 MB (Mask)	48 KB
TMP19A63CDXBG	512 KB (Mask)	24 KB

TMP19A64

NANO FLASH™



32-bit high-performance RISC microcontroller with industry's largest 2-MB Flash memory

● **TX19A CPU Core**

- Operating voltage : Internal = 1.35 to 1.65 V
Backup block = 2.5 to 3.3 V
Peripheral I/O = 1.65 to 3.3 V (external bus, I/O)
ADC = 2.7 to 3.3 V

• Maximum operating frequency: 54 MHz (13.5 MHz × 4 by PLL)

● **Built-in Functions**

- 10-bit AD converter : 24 channels (sequential comparison type, conversion time: 7.85 μs)
- DMA controller : 8 channels (memory-to-memory, memory-to-I/O, I/O-to-memory transfers)
- 16-bit timer : 11 channels (One channel can be used as a 2-phase pulse input counter.)
- 32-bit timer : 1 channel 32-bit input capture: 4 registers
32-bit output compare: 10 registers
- SIO/UART : 7 channels
- I²C/SIO : 1 channel
- Key-on wake-up : 8 channels
- External bus interface : Multiplexed/separate selectable
Address: 24 bits/Data: 16 bits, CS: 6 channels
- ROM correction : 1 word x 8 blocks, 8 words x 4 blocks
- Backup block : Backup RAM (512 bytes), time-of-day clock timer

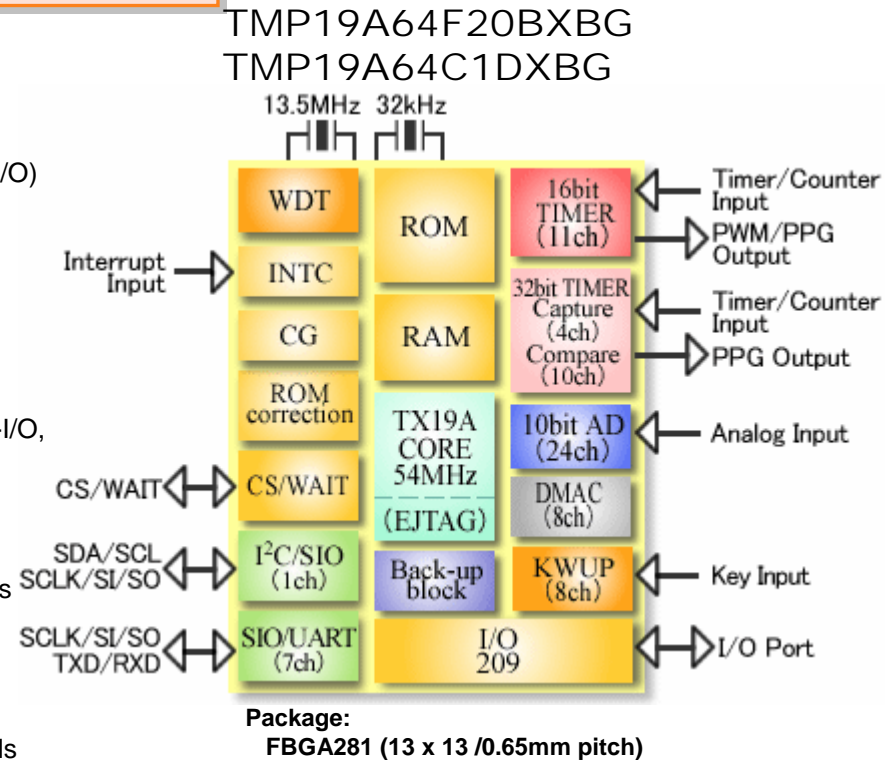

Product Lineup

Part Number	ROM	RAM
TMP19A64F20BxBG	2.0 MB (Flash)	64 KB
TMP19A64C1DXBG	1.5 MB (Mask)	56 KB

-
- The information contained herein is subject to change without notice. 021023_D
 - Toshiba is continually working to improve the quality and reliability of its products. Nevertheless, semiconductor devices in general can malfunction or fail due to their inherent electrical sensitivity and vulnerability to physical stress. It is the responsibility of the buyer, when utilizing TOSHIBA products, to comply with the standards of safety in making a safe design for the entire system, and to avoid situations in which a malfunction or failure of such TOSHIBA products could cause loss of human life, bodily injury or damage to property. In developing your designs, please ensure that TOSHIBA products are used within specified operating ranges as set forth in the most recent TOSHIBA products specifications.
Also, please keep in mind the precautions and conditions set forth in the “Handling Guide for Semiconductor Devices”, or “TOSHIBA Semiconductor Reliability Handbook” etc. 021023_A
 - The TOSHIBA products listed in this document are intended for usage in general electronics applications (computer, personal equipment, office equipment, measuring equipment, industrial robotics, domestic appliances, etc.). These TOSHIBA products are neither intended nor warranted for usage in equipment that requires extraordinarily high quality and/or reliability or a malfunction or failure of which may cause loss of human life or bodily injury (“Unintended Usage”). Unintended Usage include atomic energy control instruments, airplane or spaceship instruments, transportation instruments, traffic signal instruments, combustion control instruments, medical instruments, all types of safety devices, etc. Unintended Usage of TOSHIBA products listed in this document shall be made at the customer’s own risk. 021023_B
 - The products described in this document shall not be used or embedded to any downstream products of which manufacture, use and/or sale are prohibited under any applicable laws and regulations. 060106_Q
 - The information contained herein is presented only as a guide for the applications of our products. No responsibility is assumed by TOSHIBA for any infringements of patents or other rights of the third parties which may result from its use. No license is granted by implication or otherwise under any patents or other rights of TOSHIBA or the third parties. 070122_C
 - Please contact your sales representative for product-by-product details in this document regarding RoHS compatibility. Please use these products in this document in compliance with all applicable laws and regulations that regulate the inclusion or use of controlled substances. Toshiba assumes no liability for damage or losses occurring as a result of noncompliance with applicable laws and regulations. 060819_Z
 - The products described in this document may include products subject to the foreign exchange and foreign trade laws. 021023_F
 - The products described in this document contain components made in the United States and subject to export control of the U.S. authorities. Diversion contrary to the U.S. law is prohibited. 021023_G
 - TOSHIBA has made this document deliberately in order to make its contents as accurate as possible. Nevertheless, if any trouble should occur due to any error contained in this document, TOSHIBA shall not have any liability therefore. Also, please keep in mind the precautions and conditions set forth in the “Instruction Manual or Operation Manual of TOSHIBA Products,” or “The Precautions or Procedure Files described in the Installation Disk such as Floppy Disk or CD-ROM etc.” Please constantly pay attention to the latest information on the TOSHIBA products which is to be released through the web page of TOSHIBA microcomputer development system. (<http://www.semicon.toshiba.co.jp/eng>) 060824_N

TOSHIBA

TOSHIBA CORPORATION
Semiconductor Company
Website: <http://www.semicon.toshiba.co.jp/eng>