

TOSHIBA

Leading Innovation >>>

Microcontrollers

Toshiba Microcontrollers for Automotive Applications

~ Product Guide ~

April 2008

Rev. 1.7

**TOSHIBA CORPORATION
Semiconductor Company**

Operating Temperatures and Part Numbers

Operating Temperatures and Corresponding Part Numbers

Grade	Operating Temperatures (°C)	Example Part Number
A	-40 to 125	TMP91CMxx T
	-40 to 85	TMP91CMxx R
B	-40 to 125	TMP91CMxx S
	-40 to 85	TMP91CMxx I

In part numbers, the suffix “T” or “R” indicates Grade A products and “S” or “I” indicates Grade B products.



Quality Grade

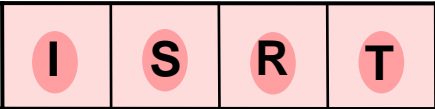

Grade A: Recommended for automotive powertrain and safety systems.

Grade B: Recommended for automotive accessories.

Toshiba offers quality grade products for automotive applications. Note)

Note) For details about the automotive grade products, please contact your local Toshiba sales representative.

TMP91CY22IFG



16-bit microcontroller with 16-Kbyte RAM and various serial interfaces

Quality Grade
(Flash = Standard quality)

I	S	R	T
---	---	---	---

● **TLCS-900/L1 CPU Core**

- Operating voltage : 2.7 to 3.6 V (27 MHz)
1.8 to 3.6 V (10 MHz)
- Minimum instruction execution time : 148 ns (27 MHz)
400 ns (10 MHz)

● **Built-in Functions**

- 10-bit AD converter : 8 channels
- UART/SIO : 1 channel
- UART/SIO/IrDA ver1.0 (115.2 kbps) : 1 channel
- I²C/SIO : 1 channel
- 8-bit timer : 8 channels
- 16-bit timer : 2 channels

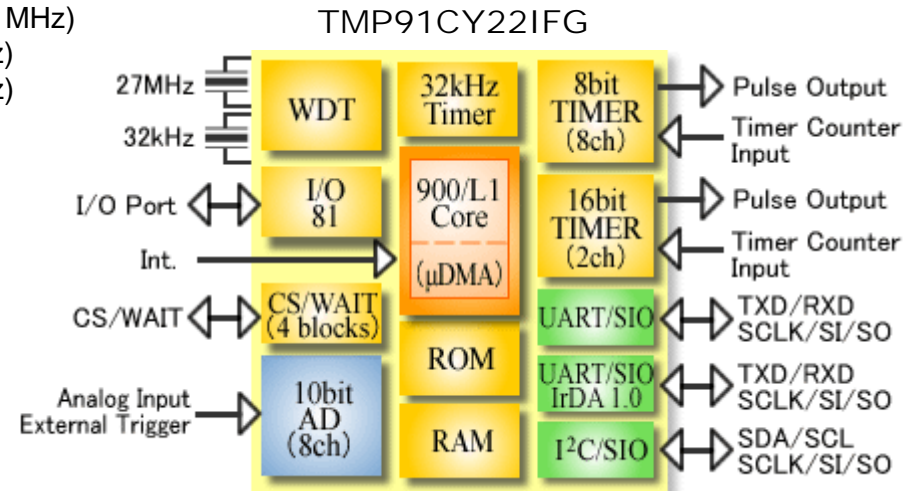

Package: LQFP100 (14 x 14mm) MASK
QFP100 (14 x 14mm) FLASH

Product Lineup

Part Number	ROM	RAM
TMP91CY22IFG	256 Kbytes	16 Kbytes
TMP91FY42FG	256 Kbytes (Flash)	16 Kbytes

● This product uses the SuperFlash® technology under license of Silicon Storage Technology, Inc. Super Flash® is a registered trademark of Silicon Storage Technology, Inc.

TMP91CU27RUG

Under development



16-bit microcontroller with various serial interfaces in compact package

Quality Grade

(Flash = Standard quality)

I	S	R	T
---	---	---	---

- **TLCS-900/L1 CPU Core**
 - Operating voltage : 2.7 to 3.6 V (27 MHz)
1.8 to 3.6V (10 MHz)
 - Minimum instruction execution time : 148 ns (27MHz)
400 ns (10 MHz)

- **Built-in Functions**
 - 10-bit AD converter : 4 channels
 - UART/SIO : 1 channel
 - UART/SIO/IrDA ver1.0 (115.2 kbps) : 1 channel
 - I²C/SIO : 1 channel
 - 8-bit timer : 6 channels
 - 16-bit timer : 1 channel

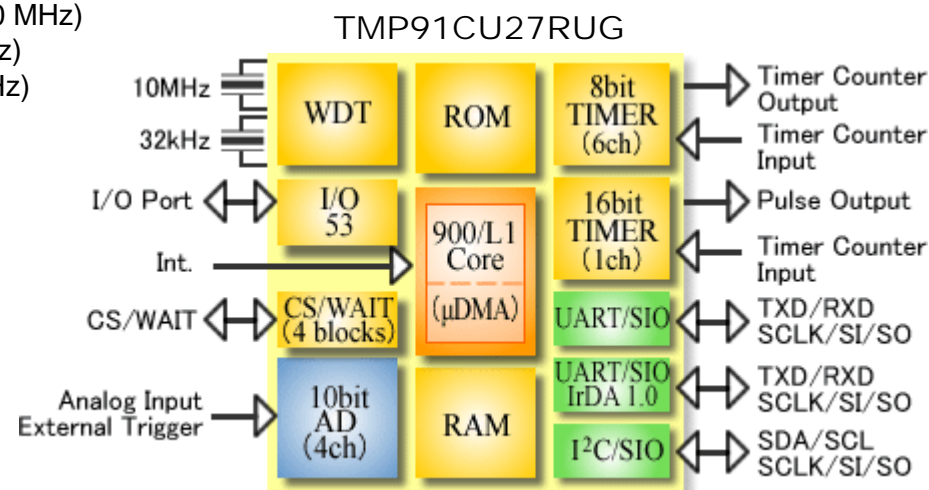

Package: LQFP64 (10 x 10mm)

Product Lineup

** : Under development

Part Number	ROM	RAM
TMP91CU27RUG**	96 Kbytes	10 Kbytes
TMP91FY27UG	256 Kbytes (Flash)	16 Kbytes

TMP92CD54IFG TMP92FD54AIFG

Under development



32-bit CAN microcontroller with 512-Kbyte ROM capable of 5V single-supply operation through use of voltage regulator and suitable for large-scale applications

Quality Grade

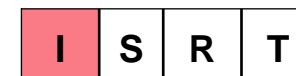

● **TLCS- 900/H1 CPU Core**

- Operating voltage : 4.5 to 5.25 V (10 MHz)
- Minimum instruction execution time : 50 ns (10 MHz)

● **Built-in Functions**

- 10-bit AD converter : 12 channels
- SIO/UART : 2 channels
- I²C/SIO : 3 channels
- SEI : 1 channel
- 8-bit timer : 8 channels
- 16-bit timer : 2 channels
- CAN controller : 1 channel
Full CAN 2.0B / 16 mailboxes

Product Lineup

Part Number	ROM	RAM
TMP92CD54IFG**	512 Kbytes	32 Kbytes
TMP92FD54AIFG**	512 Kbytes (Flash)	32 Kbytes

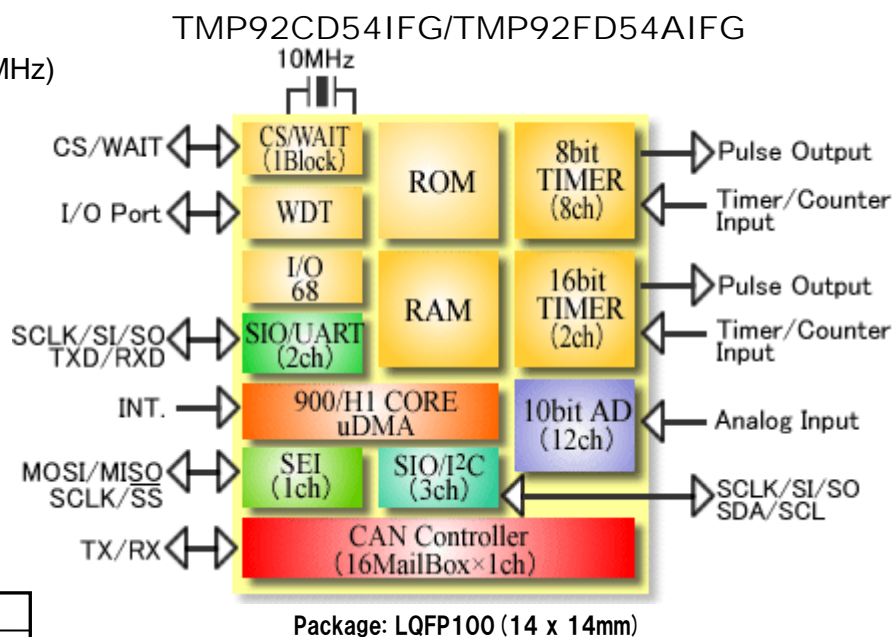

TMP86Cx08xDMG



8-bit microcontroller with two serial interfaces in compact package suitable for limited-space applications

Quality Grade

(OTP/Flash = Standard quality)

I	S	R	T
---	---	---	---

● TLCS- 870/C CPU Core

- Operating voltage : 4.5 to 5.5 V (16 MHz)
2.7 to 5.5 V (8 MHz)
- Minimum instruction execution time : 250 ns (16 MHz)

● Built-in Functions

- 8-bit AD converter : 6 channels
- UART : 1 channel
- SEI : 1 channel
- 8-bit timer : 2 channels
- 16-bit timer : 1 channel
- Key-on wake-up : 4 channels

Product Lineup

Part Number	ROM	RAM
TMP86C408IDMG	4 Kbytes	256 bytes
TMP86C408SDMG	4 Kbytes	256 bytes
TMP86C808IDMG	8 Kbytes	256 bytes
TMP86C808SDMG	8 Kbytes	256 bytes
TMP86P808DMG	8 Kbytes (OTP)	256 bytes
TMP86F808DMG	8 Kbytes (Flash)	256 bytes

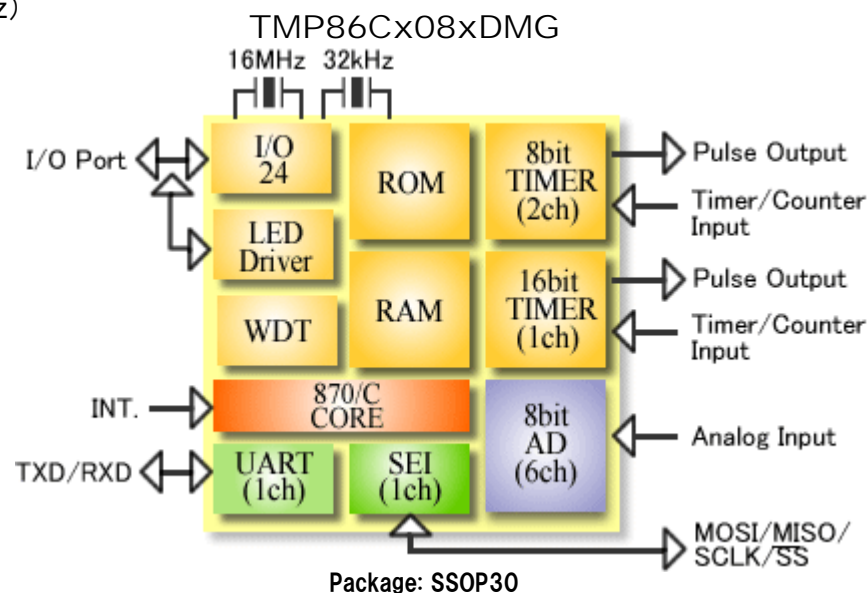

TMP86Cx47xUG



8-bit microcontroller with 10-bit AD converter and two serial interfaces in 44-pin package

Quality Grade

(OTP/Flash = Standard quality)

I	S	R	T
---	---	---	---

● TLCS- 870/C CPU Core

- Operating voltage : 4.5 to 5.5 V (16 MHz)
2.7 to 5.5 V (8 MHz)
1.8 to 5.5 V (4.2 MHz)
- Minimum instruction execution time : 250 ns (16 MHz)

● Built-in Functions

- 10-bit AD converter : 8 channels
- UART : 1 channel
- SIO : 1 channel
- 8-bit timer : 2 channels
- 16-bit timer : 1 channel
- Key-on wake-up : 4 channels

Product Lineup

Part Number	ROM	RAM
TMP86C847IUG/SUG	8 Kbytes	512 bytes
TMP86CH47IUG/SUG	16 Kbytes	512 bytes
TMP86PM47AUG	32 Kbytes (OTP)	1 Kbyte
TMP86FH47UG	16 Kbytes (Flash)	512 bytes

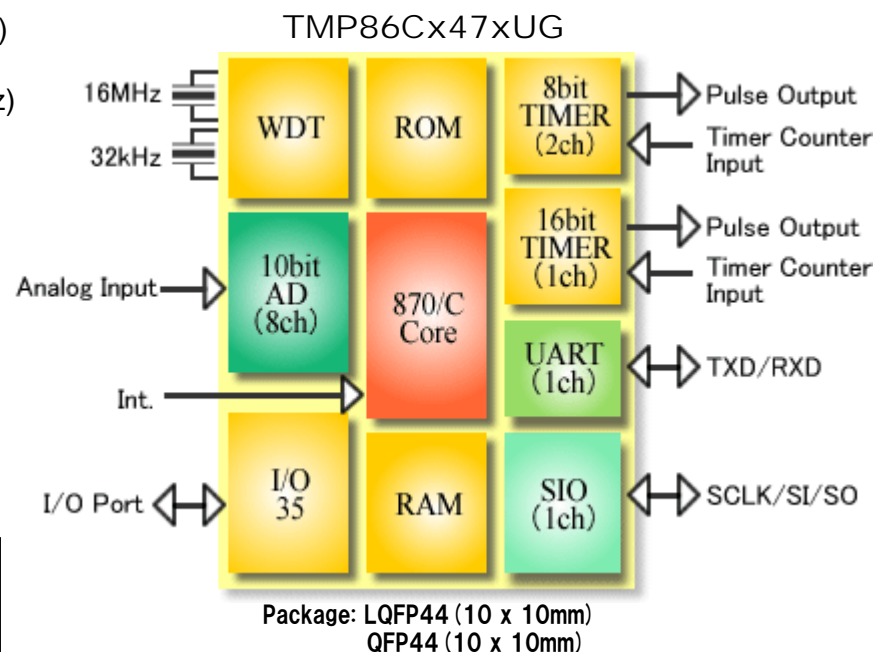

TMP86FS49AIUG TMP86FS49AIFG



8-bit microcontroller with various serial interfaces and enhanced 10-bit AD converter in 64-pin package

Quality Grade
(OTP = Standard quality)

I	S	R	T
---	---	---	---

● **TLCS- 870/C CPU Core**

- Operating voltage : 1.8 to 5.5 V (Mask/OTP)
3.0 to 5.5 V (Flash)
- Minimum instruction execution time:
 - 250 ns at 16 MHz/4.5 to 5.5 V (Mask/OTP/Flash)
 - 500 ns at 8 MHz/2.7 to 5.5 V (Mask/OTP)
3.0 to 5.5 V (Flash)
 - 950 ns at 4.2 MHz/1.8 to 5.5 V (Mask/OTP)

● **Built-in Functions**

- 10-bit AD converter : 16 channels
- UART : 2 channels
- High-speed SIO : 2 channels
- I²C : 1 channel
- 8-bit timer : 4 channels
- 16-bit timer : 2 channels
- Key-on wake-up : 4 channels

Product Lineup

Part Number	ROM	RAM
TMP86PM49UG/FG	32 Kbytes (OTP)	1 Kbyte
TMP86FS49AIUG/IFG	60 Kbytes (Flash)	2 Kbytes

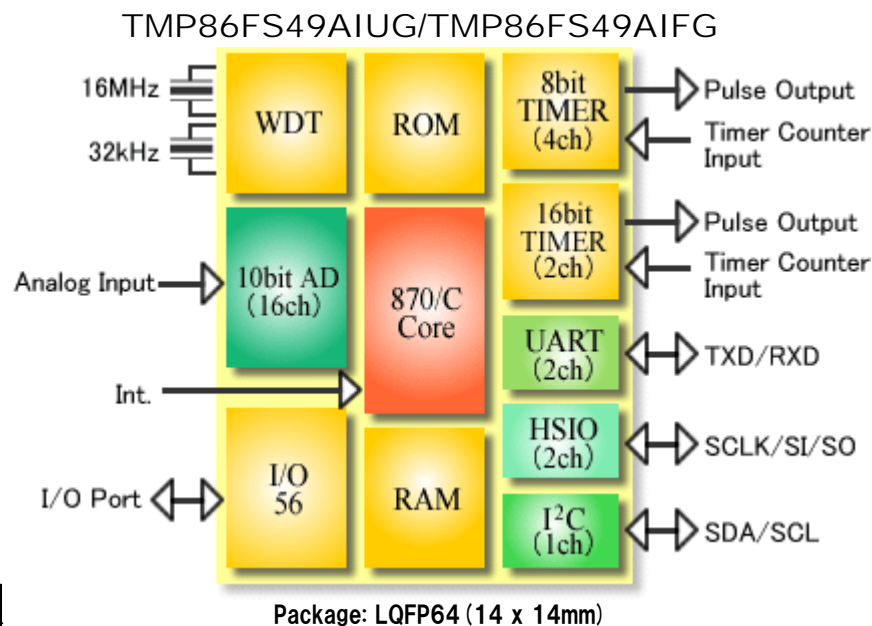

● This product uses the SuperFlash® technology under license of Silicon Storage Technology, Inc. Super Flash® is a registered trademark of Silicon Storage Technology, Inc.

TMP86xx87RUG



Compact 8-bit CAN microcontroller containing Full CAN 2.0B with 4 mailboxes and 14 channels of 10-bit AD converter in LQFP44 package

Quality Grade

I	S	R	T
---	---	---	---

● **TLCS- 870/C CPU Core**

- Operating voltage : 4.5 to 5.5 V (16 MHz)
- Minimum instruction execution time : 250 ns (16 MHz)

TMP86CH87RUG/TMP86CM87RUG
TMP86PM87RUG

● **Built-in Functions**

- 10-bit AD converter : 14 channels
- UART : 1 channel
- SEI : 1 channel
- 8-bit timer : 2 channels
- 16-bit timer : 1 channel
- CAN controller : 1 channel
Full CAN 2.0B / 4 mailboxes
- Key-on wake-up : 4 channels

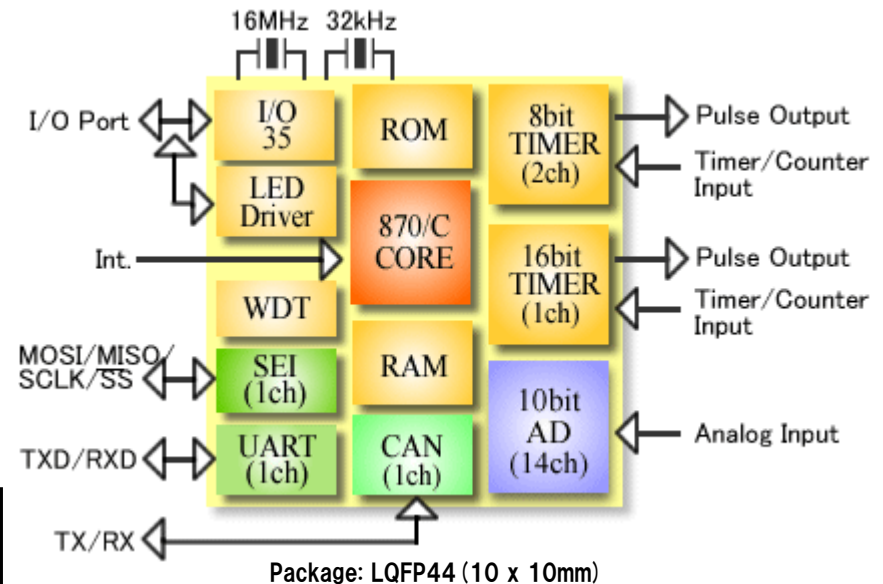

Memory Variations

Part Number	ROM	RAM
TMP86CH87RUG	16 Kbytes	1 Kbyte
TMP86CM87RUG	32 Kbytes	1 Kbyte
TMP86PM87RUG	32 Kbytes (OTP)	1 Kbyte

TMP86CH92IDMG TMP86FH92IDMG



8-bit microcontroller incorporating 10-bit AD converter, voltage detection circuit, and power-on reset circuit in compact 30-pin package

Quality Grade
(OTP = Standard quality)

I	S	R	T
---	---	---	---

- **TLCS- 870/C CPU Core**
 - Operating voltage : 4.0 to 5.5 V (16 MHz) Flash
3.0 to 5.5 V (10 MHz) Flash
4.0 to 5.5 V (16 MHz) Mask
2.7 to 5.5 V (10 MHz) Mask
 - Minimum instruction execution time : 250 ns (16 MHz)
- **Built-in Functions**
 - 10-bit AD converter : 6 channels
 - UART : 1 channel
 - SEI : 1 channel
 - I²C/UART : 1 channel
 - 8-bit timer : 2 channels
 - 16-bit timer : 1 channel
 - Key-on wake-up : 4 channels

Product Lineup

Part Number	ROM	RAM
TMP86CH92IDMG	16 Kbytes	512 bytes
TMP86FH92IDMG	16 Kbytes (Flash)	512 bytes

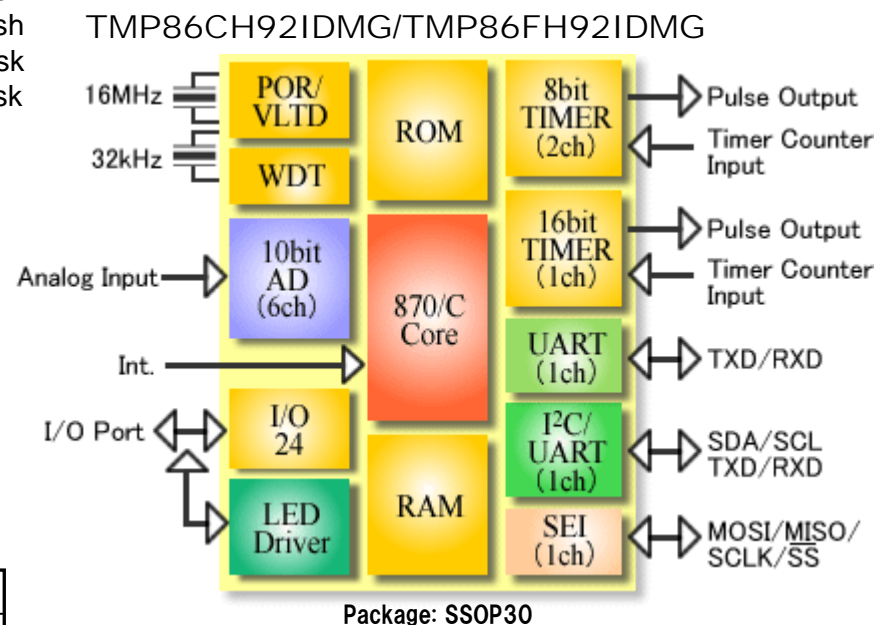

● This product uses the SuperFlash® technology under license of Silicon Storage Technology, Inc. Super Flash® is a registered trademark of Silicon Storage Technology, Inc.

TMP88CH40IMG



8-bit microcontroller containing 1 channel of PMD2 in 28-pin package ideal for low-noise, low-vibration motor control

Quality Grade
(OTP = Standard quality)

I	S	R	T
---	---	---	---

● **TLCS- 870/X CPU Core**

- Operating voltage : 4.5 to 5.5 V (20 MHz)
- Minimum instruction execution time : 200 ns (20 MHz)

● **Motor Control Circuit (PMD: Programmable Motor Driver) : 1 channel**

- Sine wave drive control
- DC motor control (sensorless, sensor-equipped)
- AC motor control (inverter control)
- Automatic commutation, automatic position detection
- Overload protection function

- 10-bit AD Converter : 4 channels
- 8-bit timer : 2 channels
- 16-bit timer : 1 channel
- SIO/UART : 1 channel

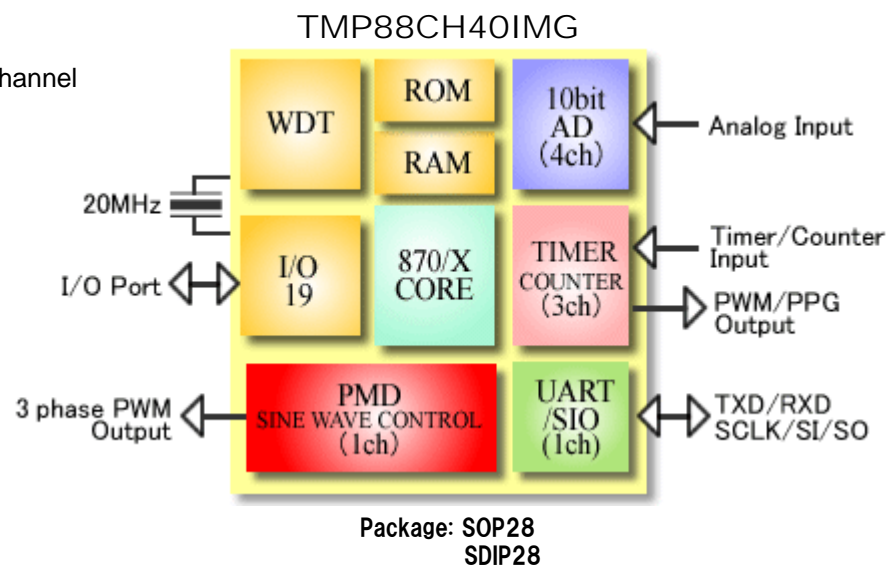

Memory Variations

Part Number	ROM	RAM
TMP88CH40IMG	16 Kbytes	512 bytes
TMP88PH40NG/MG	16 Kbytes (OTP)	512 bytes

TMP89FM82TDUG

Under development



8-bit microcontroller with improved PMD2 circuit, various communications functions, and power-on-reset circuit suitable for automotive motor control

Quality Grade

I	S	R	T
---	---	---	---

ISO/TS16949

- **TLCS- 870/C1 CPU Core**
 - Operating voltage : 4.5 to 5.5 V (8 MHz)
 - Minimum instruction execution time: 125 ns (8 MHz)
- **Motor Control Circuit (PMD: Programmable Motor Driver) : 1 channel**
 - Enhanced PWM counter resolution (24 MHz)
 - Enhanced dead-time counter resolution
 - Supports 100% commutation
 - Supports multiple maps using sine wave data registers
 - Sine wave drive circuit

DC motor control (sensorless, sensed)
 AC motor control (Inverter control)
 Overload protective function
 Auto commutation, auto position detection start

- 10-bit AD Converter : 8 channels (conversion time 10μs)
- 8-bit Timer : 4 channels
- 16-bit Timer : 2 channels
- Serial Interface : SIO/UART: 1 channel
SEI/UART: 1 channel

- On-chip debug function
- Power-on reset circuit
- Voltage detecting circuit

● This product uses the SuperFlash® technology under license of Silicon Storage Technology, Inc. Super Flash® is a registered trademark of Silicon Storage Technology, Inc.

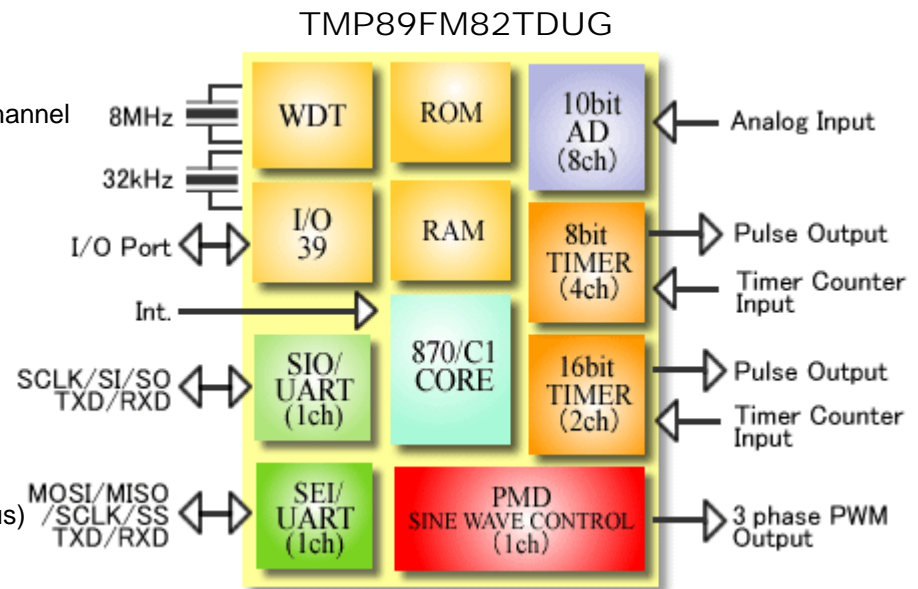

Package: LQFP48 (7 x 7mm /0.5mm pitch)

Memory Size

**Under development

Part Number	ROM	RAM
TMP89FM82TDUG**	32 Kbytes (Flash)	2 Kbytes

-
- The information contained herein is subject to change without notice. 021023_D
 - Toshiba is continually working to improve the quality and reliability of its products. Nevertheless, semiconductor devices in general can malfunction or fail due to their inherent electrical sensitivity and vulnerability to physical stress. It is the responsibility of the buyer, when utilizing TOSHIBA products, to comply with the standards of safety in making a safe design for the entire system, and to avoid situations in which a malfunction or failure of such TOSHIBA products could cause loss of human life, bodily injury or damage to property. In developing your designs, please ensure that TOSHIBA products are used within specified operating ranges as set forth in the most recent TOSHIBA products specifications. Also, please keep in mind the precautions and conditions set forth in the "Handling Guide for Semiconductor Devices", or "TOSHIBA Semiconductor Reliability Handbook" etc. 021023_A
 - The products described in this document shall not be used or embedded to any downstream products of which manufacture, use and/or sale are prohibited under any applicable laws and regulations. 060106_Q
 - The information contained herein is presented only as a guide for the applications of our products. No responsibility is assumed by TOSHIBA for any infringements of patents or other rights of the third parties which may result from its use. No license is granted by implication or otherwise under any patents or other rights of TOSHIBA or the third parties. 070122_C
 - Please contact your sales representative for product-by-product details in this document regarding RoHS compatibility. Please use these products in this document in compliance with all applicable laws and regulations that regulate the inclusion or use of controlled substances. Toshiba assumes no liability for damage or losses occurring as a result of noncompliance with applicable laws and regulations. 060819_Z

TOSHIBA

TOSHIBA CORPORATION

Semiconductor Company

Website: <http://www.semicon.toshiba.co.jp/eng>