

# **TOSHIBA**

Leading Innovation >>>

---

## Microcontrollers

# Toshiba Microcontrollers for Audio Applications

~ Product Guide ~

December 2007

Rev. 1.6

**TOSHIBA CORPORATION**  
Semiconductor Company

# TMP92CY23FG/DFG



## High-end 32-bit microcontroller for system control

- High-performance 900/H1 core
- Large-capacity memory (ROM: 256 KB, RAM: 16 KB)
- Program patch logic

### ● TLCS-900/H1 CPU Core

- Operating voltage : 3.0 to 3.6 V
- Minimum instruction execution time : 50 ns (20 MHz/3.0 to 3.6 V)

### ● Built-in Functions

- SIO/UART : 3 channels
- I<sup>2</sup>C/SIO : 2 channels
- 16-bit timer : 2 channels
- 8-bit timer : 6 channels
- 10-bit AD converter : 12 channels
- Key-on wake-up : 8 channels
- Program patch logic

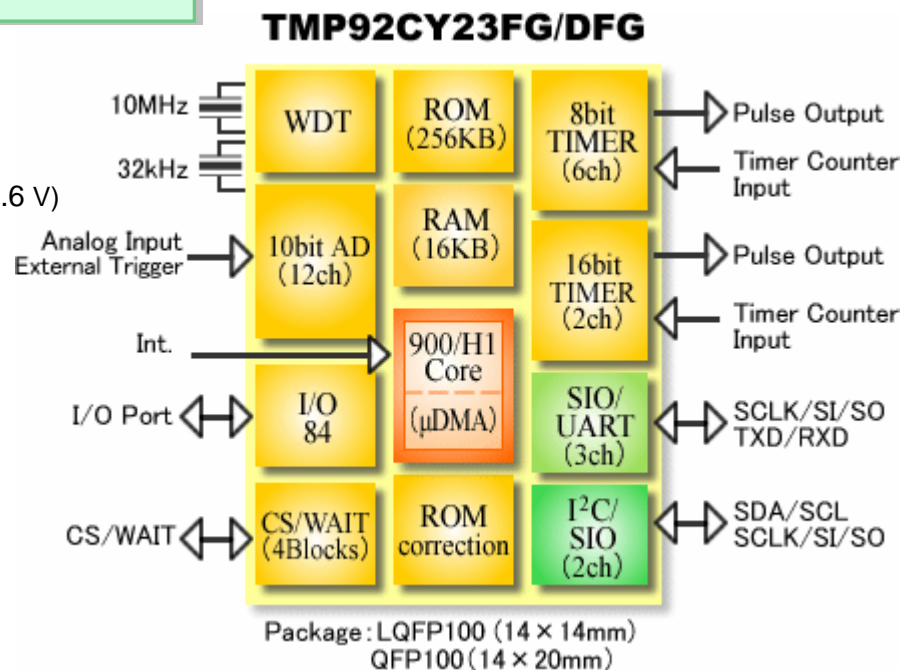

### Memory Variations

Part Number	ROM	RAM
TMP92CY23FG/DFG	256 Kbytes (Mask)	16 Kbytes
TMP92FY23FG/DFG	256 Kbytes (Flash)	16 Kbytes

# TMP91CY22FG



**16-bit microcontroller for CDMP3 control (100-pin)**

● Large-capacity memory (ROM: 256 KB, RAM: 16 KB)

● **TLCS-900/L1 CPU Core**

- Operating voltage : 1.8 to 3.6 V (Mask)  
: 2.7 to 3.6 V (Flash)
- Minimum instruction execution time : 148 ns (27 MHz/2.7 to 3.6 V)  
: 400 ns (10 MHz/1.8 to 3.6 V)

● **Built-in Functions**

- SIO/UART : 2 channels
- I<sup>2</sup>C/SIO : 1 channel
- 8-bit timer : 8 channels
- 16-bit timer : 2 channels
- 10-bit AD converter : 8 channels
- DFM (Digital Frequency Multiplier) : 1 channel

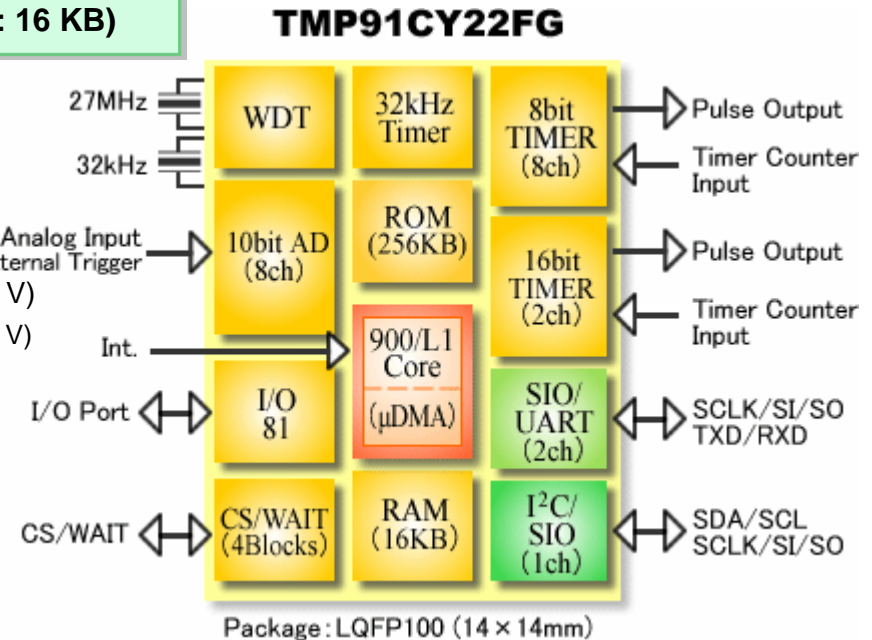

**Memory Variations**

Part Number	ROM	RAM
TMP91CW12AFG	128 Kbytes (Mask)	4 Kbytes
TMP91CY22FG	256 Kbytes (Mask)	16 Kbytes
TMP91FY42FG	256 Kbytes (Flash)	16 Kbytes

● The TMP91FY42FG does not contain the DFM circuit.

● This product uses the SuperFlash® technology under the license of Silicon Storage Technology, Inc. SuperFlash® is a registered trademark of Silicon Storage Technology, Inc.

# TMP91CW12AFG



**16-bit microcontroller for CDMP3 control (100-pin)**

- Large-capacity memory (ROM: 128 KB, RAM: 4 KB)

## ● TLCS-900/L1 CPU Core

- Operating voltage : 1.8 to 3.6 V (Mask)  
: 2.7 to 3.6 V (Flash)
- Minimum instruction execution time : 148 ns (27 MHz/2.7 to 3.6 V)  
400 ns (10 MHz/1.8 to 3.6 V)

## ● Built-in Functions

- SIO/UART : 2 channels
- I<sup>2</sup>C/SIO : 1 channel
- 8-bit timer : 8 channels
- 16-bit timer : 2 channels
- 10-bit AD converter : 8 channels
- DFM (Digital Frequency Multiplier) : 1 channel

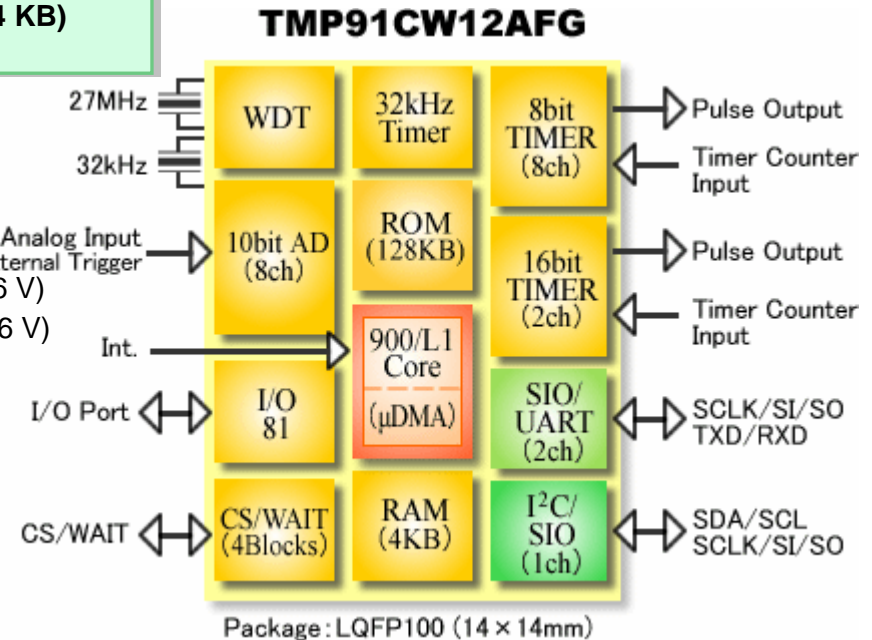

## Memory Variations

Part Number	ROM	RAM
TMP91CW12AFG	128 Kbytes (Mask)	4 Kbytes
TMP91CY22FG	256 Kbytes (Mask)	16 Kbytes
TMP91FY42FG	256 Kbytes (Flash)	16 Kbytes

● The TMP91FY42FG does not contain the DFM circuit.

● This product uses the SuperFlash® technology under the license of Silicon Storage Technology, Inc. SuperFlash® is a registered trademark of Silicon Storage Technology, Inc.

# TMP91Cx27UG



## 16-bit microcontroller for CDMP3 control (64-pin)

- Standard model
- Memory variations

### ● TLCS-900/L1 CPU Core

- Operating voltage : 1.8 to 3.6 V (Mask)  
: 2.7 to 3.6 V (Flash)
- Minimum instruction execution time: 148 ns (27 MHz/2.7 to 3.6 V)  
400 ns (10 MHz/1.8 to 3.6 V)

### ● Built-in Functions

- SIO/UART : 2 channels
- I<sup>2</sup>C/SIO : 1 channel
- 8-bit timer : 6 channels
- 16-bit timer : 1 channel
- 10-bit AD converter : 4 channels

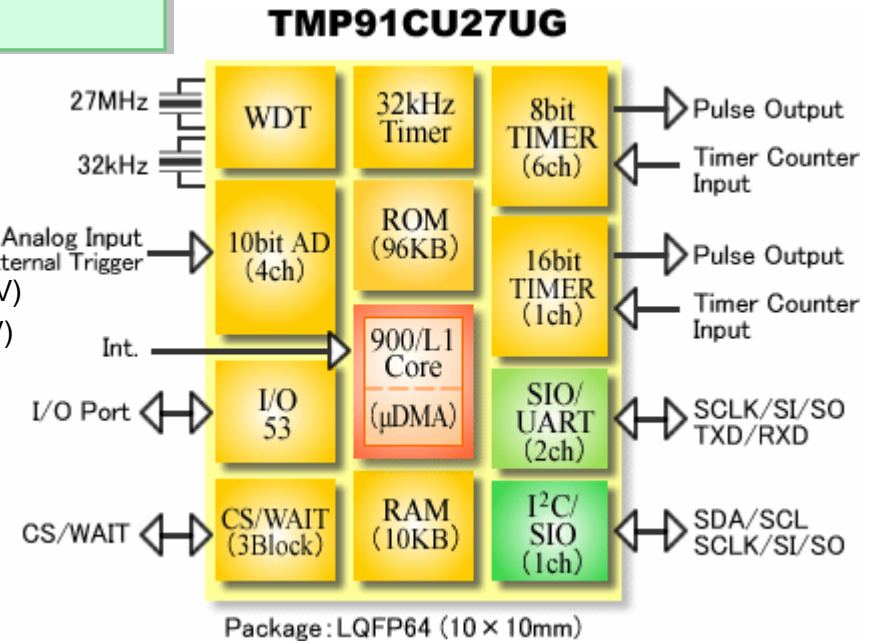

### Memory Variations

Part Number	ROM	RAM
TMP91CK27UG	24 Kbytes (Mask)	1 Kbyte
TMP91CP27UG	48 Kbytes (Mask)	4 Kbytes
TMP91CU27UG	96 Kbytes (Mask)	10 Kbytes
TMP91FY27UG	256 Kbytes (Flash)	16 Kbytes

# TMP91FW40FG



## Standard 16-bit microcontroller with LCD driver

- Large-capacity memory (ROM: 128 KB, RAM: 4 KB)
- 160 pixels (40 seg. x 4 com.)
- Not voltage booster type

### ● TLCS-900/L1 CPU Core

- Operating voltage : 2.7 to 3.6 V (Flash)  
: 1.8 to 3.6 V (Mask)
- Minimum instruction execution time : 148 ns (27 MHz/2.7 to 3.6 V)  
400 ns (10 MHz/1.8 to 3.6 V)

### ● Built-in Functions

- SIO/UART : 4 channels
- 16-bit timer : 3 channels
- 8-bit timer : 4 channels
- 10-bit AD converter : 4 channels
- Key-on wake-up : 4 channels
- Program patch logic : 6 banks
- LCD driver (not voltage booster type) : 40 seg. X 4 com.

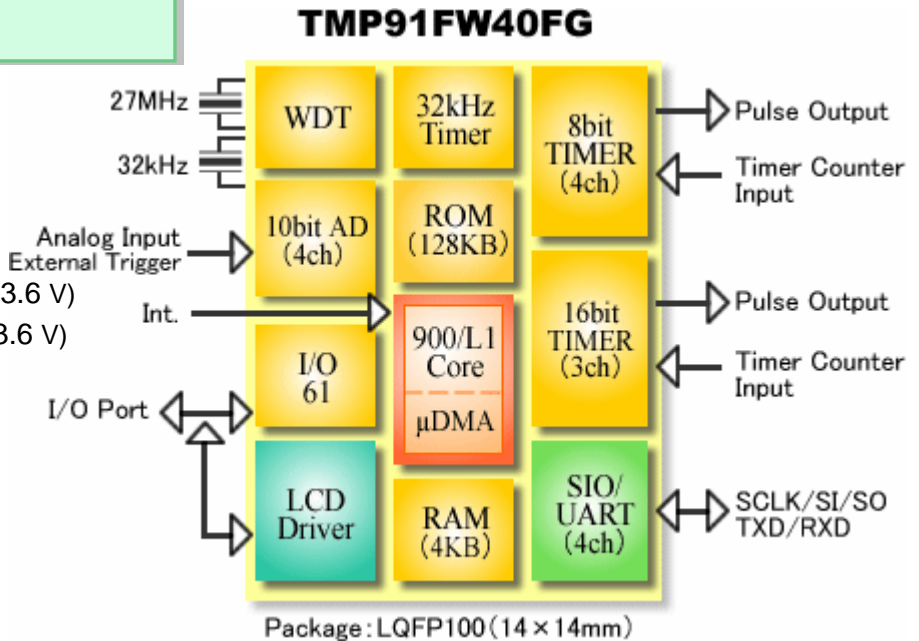

### Memory Variations

Part Number	ROM	RAM
TMP91CW40FG	128 Kbytes (Mask)	4 Kbytes
TMP91FW40FG	128 Kbytes (Flash)	4 Kbytes

● This product uses the SuperFlash® technology under the license of Silicon Storage Technology, Inc. SuperFlash® is a registered trademark of Silicon Storage Technology, Inc.

# TMP91FY42FG



**16-bit microcontroller based on 900/L1 core and containing Flash memory and various I/O functions**

## ● TLCS-900/L1 CPU Core

- Operating voltage : 2.7 to 3.6 V (Flash)  
: 1.8 to 3.6 V (Mask)
- Minimum instruction execution time : 148 ns (27 MHz/2.7 to 3.6 V)  
400 ns (10 MHz/1.8 to 3.6 V)

## ● Built-in Functions

- Flash ROM
  - Chip erase/block erase selectable
  - On-board programming (on-board boot ROM)
  - Security (read/write/password protection)
- 10-bit AD converter : 8 channels
- 8-bit timer : 8 channels
- 16-bit timer : 2 channels
- SIO/UART : 2 channels
- I<sup>2</sup>C/SIO : 1 channel

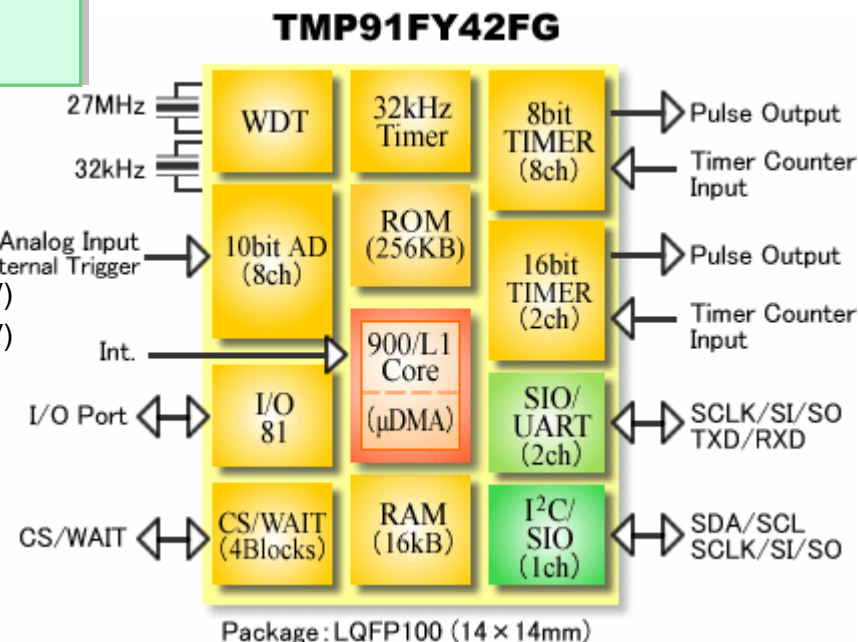

## Memory Variations

Part Number	ROM	RAM
TMP91CW12AFG	128 Kbytes (Mask)	4 Kbytes
TMP91CY22FG	256 Kbytes (Mask)	16 Kbytes
TMP91FY42FG	256 Kbytes (Flash)	16 Kbytes

● The TMP91FY42FG does not contain the DFM circuit.

● This product uses the SuperFlash® technology under the license of Silicon Storage Technology, Inc. SuperFlash® is a registered trademark of Silicon Storage Technology, Inc.

# TMP91FW60FG/DFG



16-bit microcontroller based on 900/L1 core and containing Flash memory and various I/O functions

## ● TLCS-900/L1 CPU Core

- Operating voltage : 4.5 to 5.5 V
- Minimum instruction execution time : 200 ns (20 MHz/4.5 to 5.5 V)

## ● Built-in Functions

- Flash ROM
  - Chip erase/block erase selectable
  - On-board programming (on-board boot ROM)
  - Security (read/write/password protection)
- 10-bit AD converter : 16 channels
- 8-bit timer : 6 channels
- 16-bit timer : 5 channels
- SIO/UART : 3 channels
- I<sup>2</sup>C/SIO : 2 channels

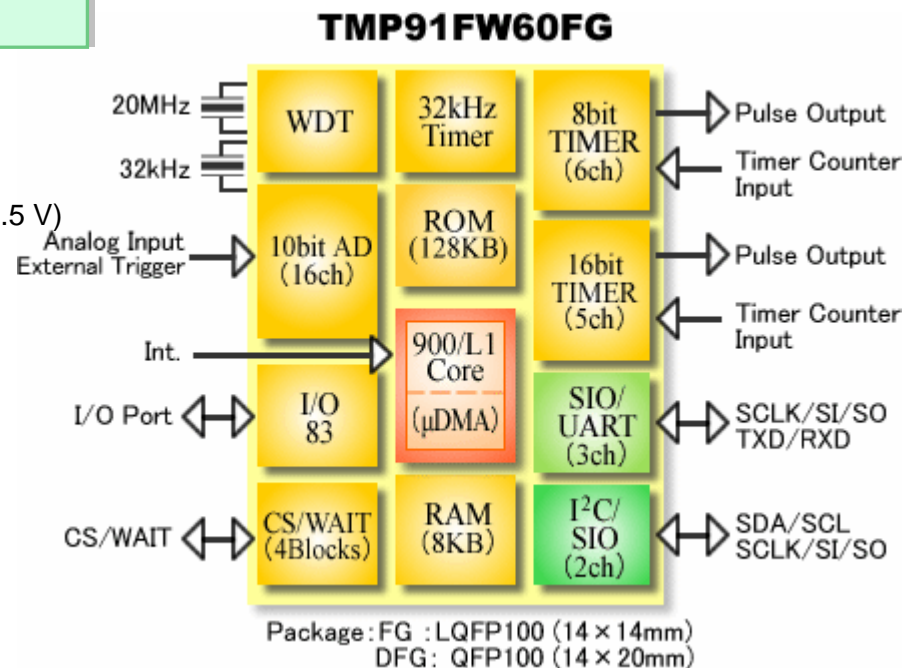

## Memory Variations

Part Number	ROM	RAM
TMP91CW60FG/DFG	128 Kbytes (Mask)	8 Kbytes
TMP91FW60FG/DFG	128 Kbytes (Flash)	8 Kbytes

● This product uses the SuperFlash® technology under the license of Silicon Storage Technology, Inc. SuperFlash® is a registered trademark of Silicon Storage Technology, Inc.

# TMP86Cx49UG/FG



## Standard 16-bit microcontroller for system control

- Low-power-consumption 870/C core
- Various serial interfaces

### ● TLCS-870/C CPU Core

- Operating voltage : 1.8 to 5.5 V (Mask/OTP)  
: 3.0 to 3.6 V, 4.5 to 5.5 V (Flash)
- Minimum instruction execution time : 250 ns (16 MHz/4.5 to 5.5 V)  
500 ns (8 MHz/2.7 to 5.5 V)  
950 ns (4.2 MHz/1.8 to 5.5 V)

### ● Built-in Functions

- UART : 2 channels
- HSIO : 2 channels
- I<sup>2</sup>C : 1 channel
- 8-bit timer : 4 channels
- 16-bit timer : 2 channels
- 10-bit AD converter : 16 channels

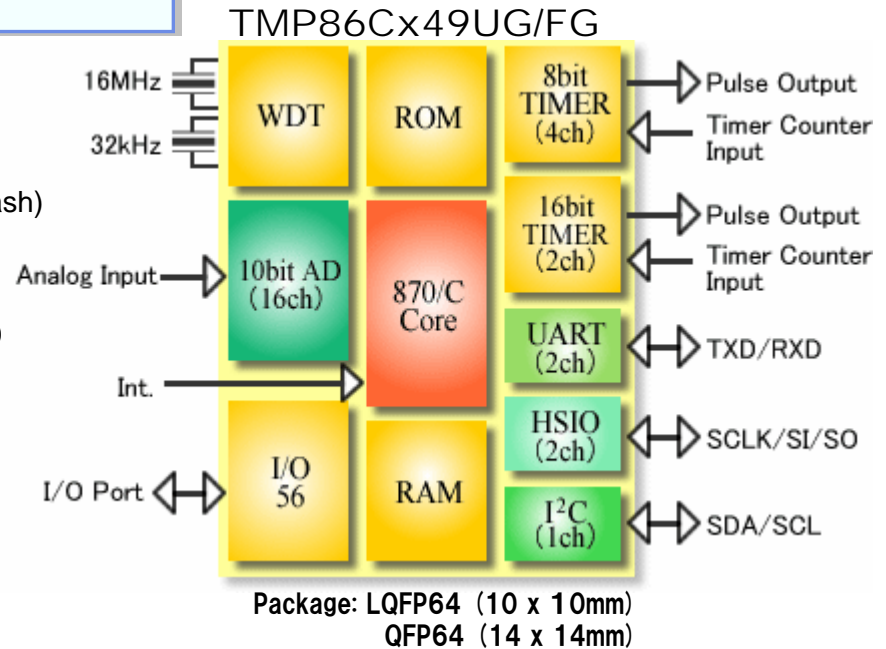

### Memory Variations

Part Number	ROM	RAM
TMP86CH49FG	16 Kbytes	512 Kbytes
TMP86CM49UG/FG	32 Kbytes	1 Kbyte
TMP86CS49UG/FG	60 Kbytes	2 Kbytes
TMP86PM49UG/FG	32 Kbytes (OTP)	1 Kbyte
TMP86FS49BUG/FG	60 Kbytes (Flash)	2 Kbytes

● This product uses the SuperFlash® technology under the license of Silicon Storage Technology, Inc. SuperFlash® is a registered trademark of Silicon Storage Technology, Inc.

# TMP86Cx25FG



## 8-bit microcontroller with dot-matrix LCD driver

- 960 pixels (60 seg. x 16 com.)
- On-chip voltage booster

### ● TLCS-870/C CPU Core

- Operating voltage : 1.8 to 5.5 V
- Minimum instruction execution time : 250 ns (16 MHz/4.5 to 5.5 V)  
500 ns (8 MHz/2.7 to 5.5 V)  
950 ns (4.2 MHz/1.8 to 5.5 V)

### ● Built-in Functions

- SIO/UART : 1 channel
- SIO : 1 channel
- 18-bit timer : 1 channel
- 8-bit timer : 4 channels
- 8-bit AD converter : 8 channels
- LCD driver (On-chip voltage booster): 60 seg. X 16 com.

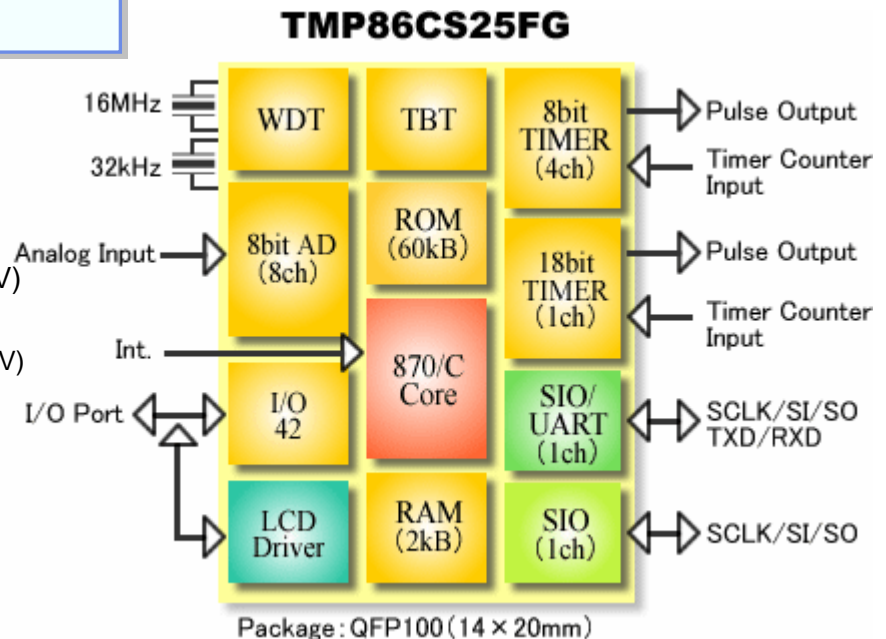

### Memory Variations

Part Number	ROM	RAM
TMP86CM25FG	32 Kbytes	2 Kbytes
TMP86CS25FG	60 Kbytes	2 Kbytes
TMP86PS25FG	60 Kbytes (OTP)	2 Kbytes

# TMP86Cx29BUG/BFG



## Standard 8-bit microcontroller with LCD driver

- 128 pixels (32 seg. x 4 com.)
- On-chip voltage booster

### ● TLCS-870/C CPU Core

- Operating voltage : 1.8 to 5.5 V
- Minimum instruction execution time : 250 ns (16 MHz/4.5 to 5.5 V)  
500 ns (8 MHz/2.7 to 5.5 V)  
950 ns (4.2 MHz/1.8 to 5.5 V)

### ● Built-in Functions

- SIO/UART : 1 channel
- 18-bit timer : 1 channel
- 8-bit timer : 4 channels
- 10-bit AD converter : 8 channels
- LCD driver (On-chip voltage booster): 32 seg. X 4 com.

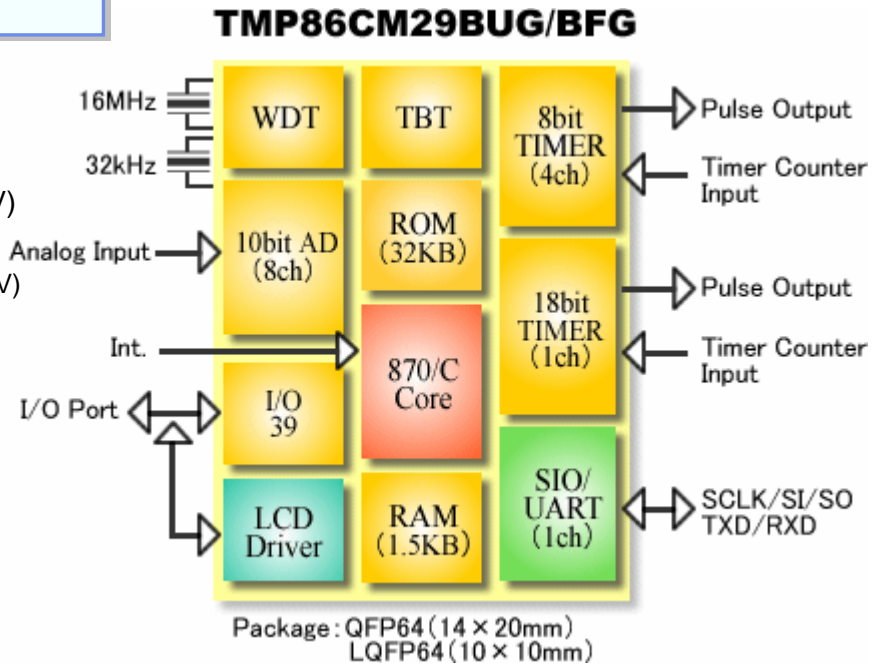

### Memory Variations

Part Number	ROM	RAM
TMP86C829BUG/BFG	8 Kbytes	0.5 Kbytes
TMP86CH29BUG/BFG	16 Kbytes	1.5 Kbytes
TMP86CM29BUG/BFG	32 Kbytes	1.5 Kbytes
TMP86PM29BUG/BFG	32 Kbytes (OTP)	1.5 Kbytes

- 
- The information contained herein is subject to change without notice. 021023\_D
  - Toshiba is continually working to improve the quality and reliability of its products. Nevertheless, semiconductor devices in general can malfunction or fail due to their inherent electrical sensitivity and vulnerability to physical stress. It is the responsibility of the buyer, when utilizing TOSHIBA products, to comply with the standards of safety in making a safe design for the entire system, and to avoid situations in which a malfunction or failure of such TOSHIBA products could cause loss of human life, bodily injury or damage to property. In developing your designs, please ensure that TOSHIBA products are used within specified operating ranges as set forth in the most recent TOSHIBA products specifications.  
Also, please keep in mind the precautions and conditions set forth in the "Handling Guide for Semiconductor Devices", or "TOSHIBA Semiconductor Reliability Handbook" etc. 021023\_A
  - The TOSHIBA products listed in this document are intended for usage in general electronics applications (computer, personal equipment, office equipment, measuring equipment, industrial robotics, domestic appliances, etc.). These TOSHIBA products are neither intended nor warranted for usage in equipment that requires extraordinarily high quality and/or reliability or a malfunction or failure of which may cause loss of human life or bodily injury ("Unintended Usage"). Unintended Usage include atomic energy control instruments, airplane or spaceship instruments, transportation instruments, traffic signal instruments, combustion control instruments, medical instruments, all types of safety devices, etc. Unintended Usage of TOSHIBA products listed in this document shall be made at the customer's own risk. 021023\_B
  - The products described in this document shall not be used or embedded to any downstream products of which manufacture, use and/or sale are prohibited under any applicable laws and regulations. 060106\_Q
  - The information contained herein is presented only as a guide for the applications of our products. No responsibility is assumed by TOSHIBA for any infringements of patents or other rights of the third parties which may result from its use. No license is granted by implication or otherwise under any patent or patent rights of TOSHIBA or others. 021023\_C
  - Please contact your sales representative for product-by-product details in this document regarding RoHS compatibility. Please use these products in this document in compliance with all applicable laws and regulations that regulate the inclusion or use of controlled substances. Toshiba assumes no liability for damage or losses occurring as a result of noncompliance with applicable laws and regulations. 060819\_Z
  - The products described in this document may include products subject to the foreign exchange and foreign trade laws. 021023\_F
  - The products described in this document contain components made in the United States and subject to export control of the U.S. authorities. Diversion contrary to the U.S. law is prohibited. 021023\_G
  - TOSHIBA has made this document deliberately in order to make its contents as accurate as possible. Nevertheless, if any trouble should occur due to any error contained in this document, TOSHIBA shall not have any liability therefore. Also, please keep in mind the precautions and conditions set forth in the "Instruction Manual or Operation Manual of TOSHIBA Products," or "The Precautions or Procedure Files described in the Installation Disk such as Floppy Disk or CD-ROM etc." Please constantly pay attention to the latest information on the TOSHIBA products which is to be released through the web page of TOSHIBA microcomputer development system. (<http://www.semicon.toshiba.co.jp/eng>) 060824\_N

# TOSHIBA

**TOSHIBA CORPORATION**  
Semiconductor Company  
Website: <http://www.semicon.toshiba.co.jp/eng>