

TOSHIBA

Leading Innovation >>>

eye

b

TOSHIBA SEMICONDUCTOR BULLETIN eye May 2008 VOLUME 189

CONTENTS

New Products

Intelligent analog-based control solution:
Mixed-Signal Controllers 2

High-performance stream processor:
SpursEngine™ SE1000 4

NEW PRODUCTS
1

Intelligent analog-based control solution Mixed-Signal Controllers

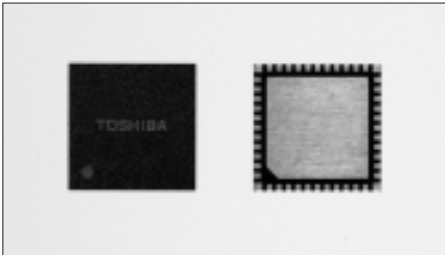

Toshiba has a new concept mixed-signal controller for the purpose of reducing the number of board components, by facilitating adjustment of sensor devices using software and incorporating peripheral circuits in the controller for applications in the sensor market and a wide range of application devices using sensors, including cell phones and home appliances.

Various devices are used for sensors installed in home appliances and other applications, including acceleration sensors and temperature sensors, according to the purpose and location of their use. In the past, it was necessary to design and adjust the boards according to each device and model, in order to convert analog information from the devices into information usable by the product in which it is incorporated. As a result, production costs rose due to increases in the number of board components and development efficiency was hindered due to the need to confirm characteristics between components.

This newly developed mixed-signal controller integrates analog circuits for processing information incorporated from acceleration, temperature and other types of sensors, and a function for controlling those analog circuits with software, on a single chip. In addition to enabling the number of components to be reduced by 20% to 50% during the course of board fabrication for different types of sensors and application models, which had previously placed a heavy burden on developers, development efficiency in terms of adjustment can be improved from 20% to 50%. Furthermore, since correction of signal output from devices and adjustment of timing can be performed with software, this mixed-signal controller makes it easy to accommodate functional modifications even after shipment.

Solutions Using On-Chip Analog Circuits and Embedded Software

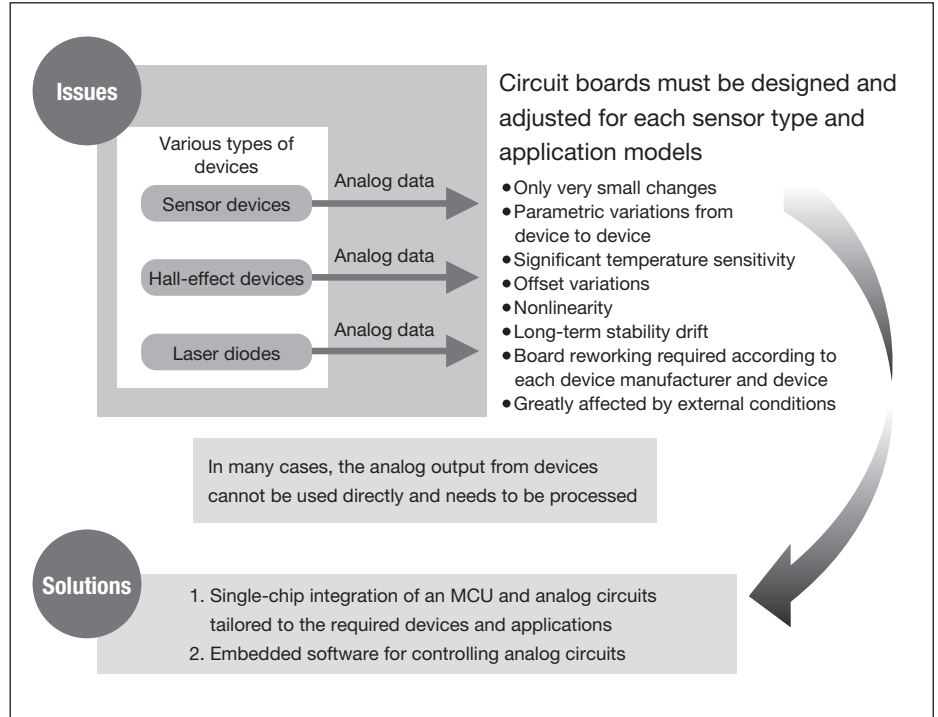

Mixed-Signal Controllers

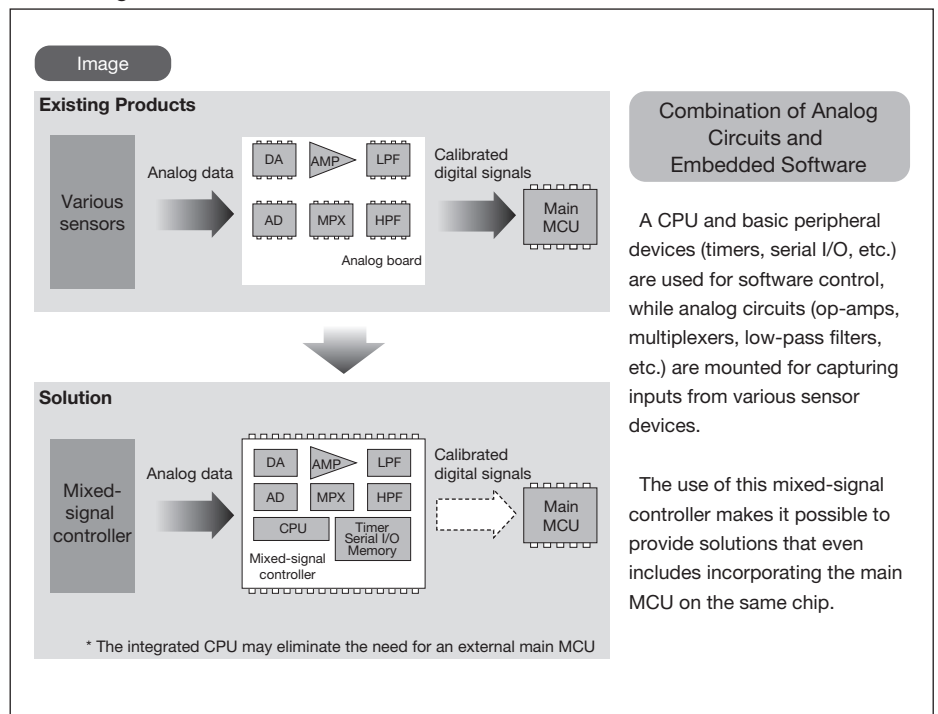

■Main Specifications of the First Product in the General-Purpose Product Lineup

| | |
|---------------------------|---|
| Supply voltage | 2.2V-3.6V |
| Operating frequency range | 4-5MHz, 400 kHz (Both high frequency and low frequency are embedded) |
| Supply current (typ.) | IDD-Standby= 7μA IDD-operation=550μA@Sampling=100Hz |
| On-chip memory | FLASH:16KB, RAM:256B |
| Peripherals | On-chip debugging, power-on reset, serial communication (I ² C, etc.), 16-bit timer |
| Analog circuits | 10-bit A/D converter, op-amp (two-stage), offset controller, low-pass filter, 3D sequential controller |
| Package | VQON44 (5.3 mm x 5.3 mm, 0.65 mm thickness), WLCSP (3.5 mm x 3.5 mm, 0.9 mm thickness), bare chips also available |

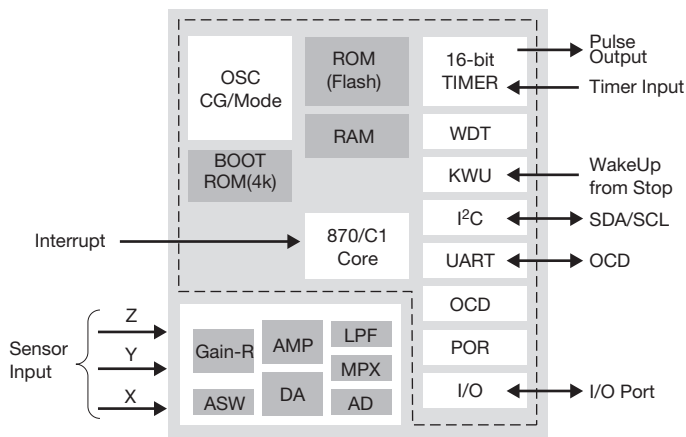

■Product Roadmap

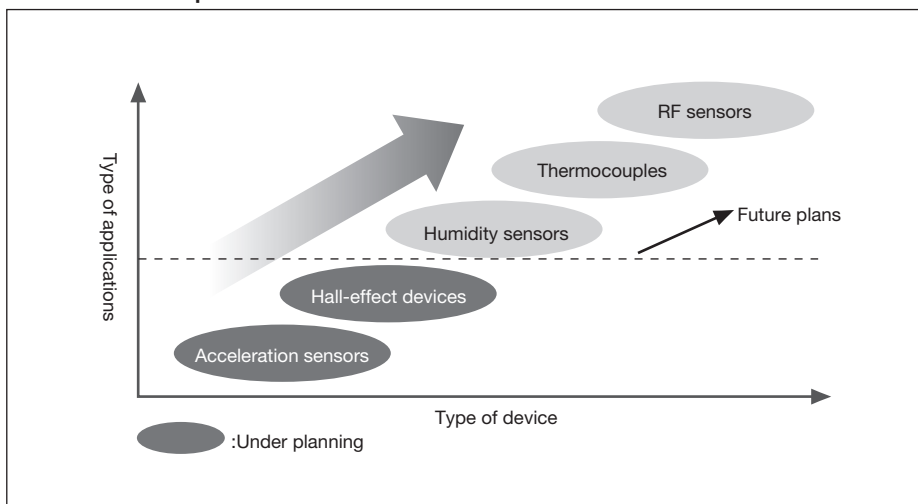

The first product in this newly developed lineup of general-purpose devices will begin sample shipment in the end of 2008. There are plans to develop additional products equipped with interfaces compatible with various types of sensors as well as mixed analog circuit products for various types of applications.

A demo board of this product was shown at Sensor Expo Japan 2008 (held from April 23 to 25 at the Tokyo Big Sight) and at the ESEC Embedded Systems Expo (held from May 14 to May 16 at the Tokyo Big Sight).

Features

- 1 Direct incorporation of detection signals from bridge resistor type sensors.
- 2 Adjustment and correction of detection signals, including offset correction and averaging, with embedded software.
- 3 Realizes operations corresponding to applications using embedded software, including operational control based on detection signals, setting of detection timing, and setting of output format.
- 4 By rewriting software, modification of functions can be easily done even after the device has been mounted on the board.
- 5 Sample software available.

Offering development environment to advance stream processing applications in the Full- HD era High-performance Stream Processor: SpursEngine™ SE1000

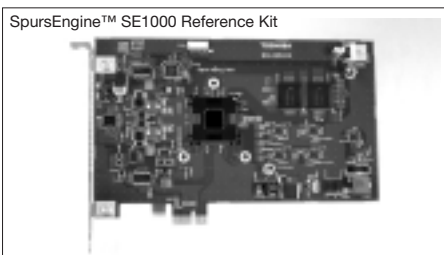
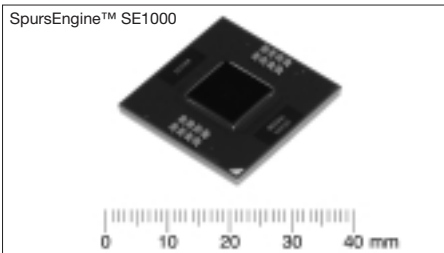

Toshiba has started sample shipping of the SpursEngine™ SE1000 (SpursEngine™), a high-performance stream processor integrating four Synergistic Processing Element (SPE) cores derived from the "Cell Broadband Engine™" (Cell/B.E.™). At the same time, a comprehensive reference kit will be provided to support developers working on SpursEngine™ applications.

SpursEngine™ is a co-processor that integrates a hardware codec for Full HD encoding and decoding of MPEG-2 and H.264 streams with four SPEs derived from Cell/B.E. These advanced processing elements offer high performance media streaming capabilities, with a clock frequency of 1.5GHz, while achieving low power consumption range of 10W to 20W. The design of this powerful co-processor is dedicated to bringing the advanced capabilities of the Cell/B.E.™ to consumer electronics, particularly video processing in digital consumer products.

Toshiba will support developers working on SpursEngine™ applications with a comprehensive reference kit that includes a reference board and essential middleware APIs. The reference board has a PCI-Express edge connector that can connect to an x1 layer slot in a PC. Toshiba will also provide an

integrated development environment (SPE compiler, SPE debugger, and performance monitor) and sample applications that demonstrate how to use the provided middleware. With the reference kit, customers can quickly and easily construct an evaluation and development environment and accelerate product development.

Toshiba will further boost the performance and cut the power consumption of the SpursEngine™, towards supporting further innovation in products offering new levels of functionality.

Also, Toshiba is developing co-operative relationships with many partner companies in

order to develop wide scope video solutions that utilize SpursEngine™. For example, we are partnering with Corel Corporation whose headquarters are in Canada; and Taiwan based CyberLink Corporation and Leadtek Research Inc. These companies produce popular video and image processing software and hardware such as graphic boards, and will together supply to set manufactures. By working together with these companies and creating a new value chain, many end users can enjoy comfortable digital life by using our board and software bundled with SpursEngine™.

■Outline of SpursEngine™ SE1000

| | |
|----------------------|---|
| Product number | BXA32110XBGN |
| Processor | SPE 4 core |
| SPE | Fully compliant with Cell/B.E.™ SPE Instruction Set SIMD RISC/Single & double -precision floating-point arithmetic /DMAC/MMU |
| Memory interface | (XDR™ DRAM) 128MB(512Mbit x2), Physical bandwidth of 12.8GB/s |
| Hardware Video Codec | Full HD capable MPEG2 Encoder and Decoder Full HD capable H.264 Encoder and Decoder |
| PCI-Express I/F | x1, x4 PCI-Express compliant with Base Specification Revision 1.1 |

■Outline of SpursEngine™ Reference Kit

| | | SpursEngine™ SE1000 Reference Kit | | |
|--------------------|--|--|--------------------------------|--|
| Hardware | Product name | SpursEngine™ SE1000 Reference Kit | | |
| | Model | BXX005000 | | |
| | Main engine SpursEngine™ SE1000 | Processing performance | Maximum 48Gflops 12Gflops/1SPE | |
| | | Element core | SPEx4 | |
| | | Operating frequency | 1.5GHz | |
| | | Registers | 128bit x 128/1SPE | |
| | Host interface PCI-Express | Internal memory | Local storage 256KB/1SPE | |
| Functions | | Endpoint 1 lane link support Compliant Base specification, Revision 1.1 | | |
| Memory XDR™DRAM | Physical bandwidth | 12.8GB/s | | |
| | Memory size | 128MB | | |
| Software | Basic software, libraries and tool chain for host and SPE program development. Sample applications for user programs. | | | |

*XDR™ DRAM is a trademark of Rambus Inc. in the United States and other countries.

*SpursEngine™ and the logo are trademarks of Toshiba Corporation.

*Cell Broadband Engine™ and Cell/B.E.™ are trademarks of Sony Computer Entertainment Inc.

The information contained herein is subject to change without notice.

The information contained herein is presented only as a guide for the applications of our products. No responsibility is assumed by TOSHIBA for any infringements of patents or other rights of the third parties which may result from its use. No license is granted by implication or otherwise under any patent or patent rights of TOSHIBA or others.

TOSHIBA is continually working to improve the quality and reliability of its products. Nevertheless, semiconductor devices in general can malfunction or fail due to their inherent electrical sensitivity and vulnerability to physical stress. It is the responsibility of the buyer, when utilizing TOSHIBA products, to comply with the standards of safety in making a safe design for the entire system, and to avoid situations in which a malfunction or failure of such TOSHIBA products could cause loss of human life, bodily injury or damage to property. In developing your designs, please ensure that TOSHIBA products are used within specified operating ranges as set forth in the most recent TOSHIBA products specifications. Also, please keep in mind the precautions and conditions set forth in the "Handling Guide for Semiconductor Devices," or "TOSHIBA Semiconductor Reliability Handbook" etc.

The TOSHIBA products listed in this document are intended for usage in general electronics applications (computer, personal equipment, office equipment, measuring equipment, industrial robotics, domestic appliances, etc.). These TOSHIBA products are neither intended nor warranted for usage in equipment that requires extraordinarily high quality and/or reliability or a malfunction or failure of which may cause loss of human life or bodily injury ("Unintended Usage"). Unintended Usage include atomic energy control instruments, airplane or spaceship instruments, transportation instruments, traffic signal instruments, combustion control instruments, medical instruments, all types of safety devices, etc. Unintended Usage of TOSHIBA products listed in this document shall be made at the customer's own risk.

TOSHIBA products should not be embedded to the downstream products which are prohibited to be produced and sold, under any law and regulations.